

FITTING INSTRUCTION

Clamp mark in acc. with		Cables joining
ISO	PN	
1	L	Left directional lights
2	+	Rear fog lights
3	31	Ground
4	R	Right directional lights
5	58R	Right side parking lights
6	54	Stoplights
7	58L	Left side parking lights

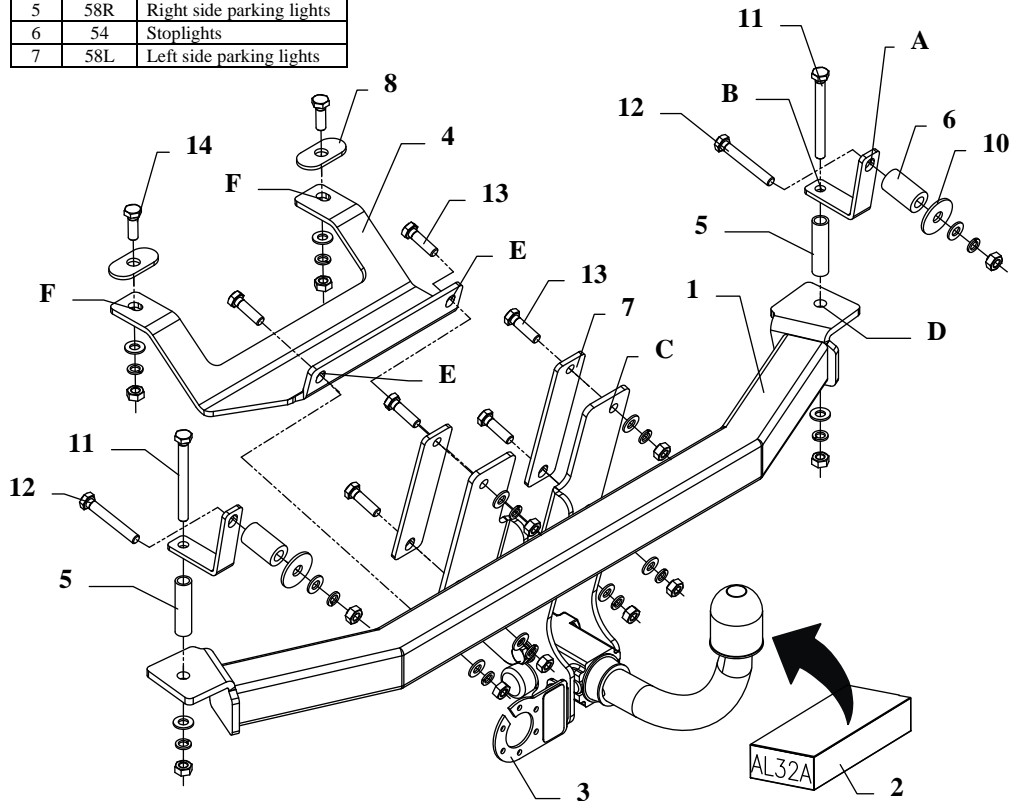

This towing hitch is designed to assembly in following car: **ALFA ROMEO 146, 5 doors**, produced since 1995 till 2001, catalogue no. **AL32A** and is prepared to tow trailers max total weight **1300 kg** and max vertical load **75 kg**.

From manufacturer

Thank you for buying our product. Their reliability has been confirmed in many tests. Reliability of towing hitch depends also on correct assembly and correct exploitation. For this reasons we kindly ask to read carefully this instruction and apply to hints.

The towing hitch should be install in points described by a car producer.

The instruction of the assembly

1. Disassemble a spare wheel, carpet, rear panel cover and side carpets.
2. In rear panel (inside), under sound proof layer are four factory marked points. Find them and drill holes $\varnothing 10,5$ mm.
3. From below the car (in left and right chassis member) are holes $\varnothing 18$ mm. Through this holes drill another holes to trunk interior using bit $\varnothing 10,5$ mm (make very carefully).
4. To made holes put angle fish-plates (pos. 9), and next through hole (pos. A) in angle fish-plate (pos. 9) mark point on rear panel. In this point drill hole $\varnothing 25$ mm. In made holes slip distance sleeves $\varnothing 25 \times \varnothing 15 \times 43$ mm (pos. 6) and put angle fish-plate (pos. 9) again. Put bolt M10x100mm (pos. 11) through hole (pos. B) and through hole (pos. A) bolt M10x70mm (pos. 12). Fix loosely with distance sleeve (pos. 6) as shown in the drawing.
5. Put the main bar of towing hitch (pos. 1) between bumper and rear panel, fix through hole (pos. C) and fish plates (pos. 7) using bolts M10x35mm (pos. 13). Through holes (pos. D) slip distance sleeves $\varnothing 17 \times 2,35$ mm, L=64mm (pos. 5) below the car. Fix with bolts M10x100mm (pos. 11).
6. To the main bar of towing hitch (pos. 1), through hole (pos. E) fix bracket (pos. 4) using bolts M10x35mm (pos. 13), next through holes (pos. F) drill to trunk interior holes using bit $\varnothing 10,5$ mm and fix all using bolts M10x30mm (pos. 14) -use washers (pos. 8).
7. Fix body of the automat and the socket plate (pos. 3) according to supplied instruction.
8. Tighten all bolts according to the torque shown in the table.
9. Connect electric wires of 7-poles socket according to the instruction of the car. (Recommend to make at authorized service station)
10. Complete paint layer damaged during installation.

Torque settings for nuts and bolts (8,8):

M6 - 11 Nm	M8 - 25 Nm	M10 - 50 Nm
M12 - 87 Nm	M14 - 138 Nm	M16 - 210 Nm











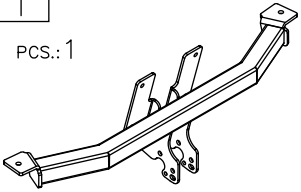

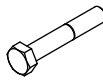

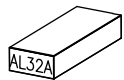
NOTE

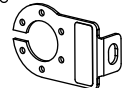
After install the towing hitch you should get adequate note in registration book (at authorised service station).The car should be equipped with:

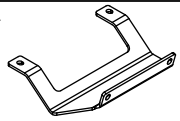
- Indicators
- Tow mirrors

After 1000km of exploitation check all bolts. The ball of towing hitch must be always kept clear and conserve with a grease.

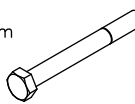
Towing hitch accessories:

Pos. 1 Main bar PCS.: 1		Pos. 6 Distance sleeve ø25xø15mm L=43mm PCS.: 2		Pos. 12 Bolt 8,8 B M10x70mm PCS.: 2	
		Pos. 7 Fish-plate 180x40x5mm PCS.: 2		Pos. 13 Bolt 8,8 B M10x35mm PCS.: 6	
Pos. 2 Tow ball PCS.: 1		Pos. 8 Ovate washer 60x30x4mm PCS.: 2		Pos. 14 Bolt 8,8 B M10x30mm PCS.: 2	
Pos. 3 Socket plate PCS.: 1		Pos. 9 Angle fish-plate 86x83x25mm PCS.: 2		Pos. 15 Nut 8 B M10 PCS.: 12	
Pos. 4 Bracket PCS.: 1		Pos. 10 Washer ø30xø10,5x2,5mm PCS.: 2		Pos. 16 Plain washer ø10mm PCS.: 12	
Pos. 5 Distance sleeve ø17.2x2.35mm L=64mm PCS.: 2		Pos. 11 Bolt 8,8 B M10x100mm PCS.: 2		Pos. 17 Spring washer ø10mm PCS.: 12	



PPUH AUTO-HAK Sp.J.

Produkcja Zaczepów Kulowych
Henryk & Zbigniew Nejman
76-200 SŁUPSK ul. Słoneczna 16K
tel/fax (059) 8-414-414; 8-414-413
E-mail: office@autohak.com.pl
www.autohak.com.pl

Towing hitch (without electrical set)

Class: **A50-X** Cat. no. **AL32A**

Designed for:

Manufacturer: **ALFA ROMEO**

Model: **146**

Type: **5 doors**

produced since 1995 till 2001

Technical data:

D-value: 7,80 kg

maximum trailer weight: **1300 kg**

maximum vertical cup load: **75 kg**

Approval number according to Directive 94/20/EC: e20*94/20*0336*00

Foreword

This towing hitch is designed according to rules of safety traffic regulations. The towing hitch is a safety component and can be install only by qualified personnel. Any alteration or conversion of the towing hitch is prohibited and would lead to cancellation of design certification. Remove insulating compound and underseal from vehicle (if present) in the areas of the matting surfaces of the towing hitch. The vehicle manufacturer's specifications regarding trailer load and max. vertical cup mass are decisive for driving whereat values for the towing hitch cannot be exceeded.

D-value formula:

$$\frac{\text{Max trailer weight [kg]} \times \text{Max vehicle weight [kg]}}{\text{Max trailer weight [kg]} + \text{Max vehicle weight [kg]}} \times \frac{9,81}{1000} = D \text{ [kN]}$$