

FITTING INSTRUCTION

Clamp mark in acc. with		Cables joining
ISO	PN	
1	L	Left directional lights
2	+	Rear fog lights
3	31	Ground
4	R	Right directional lights
5	58R	Right side parking lights
6	54	Stoplights
7	58L	Left side parking lights

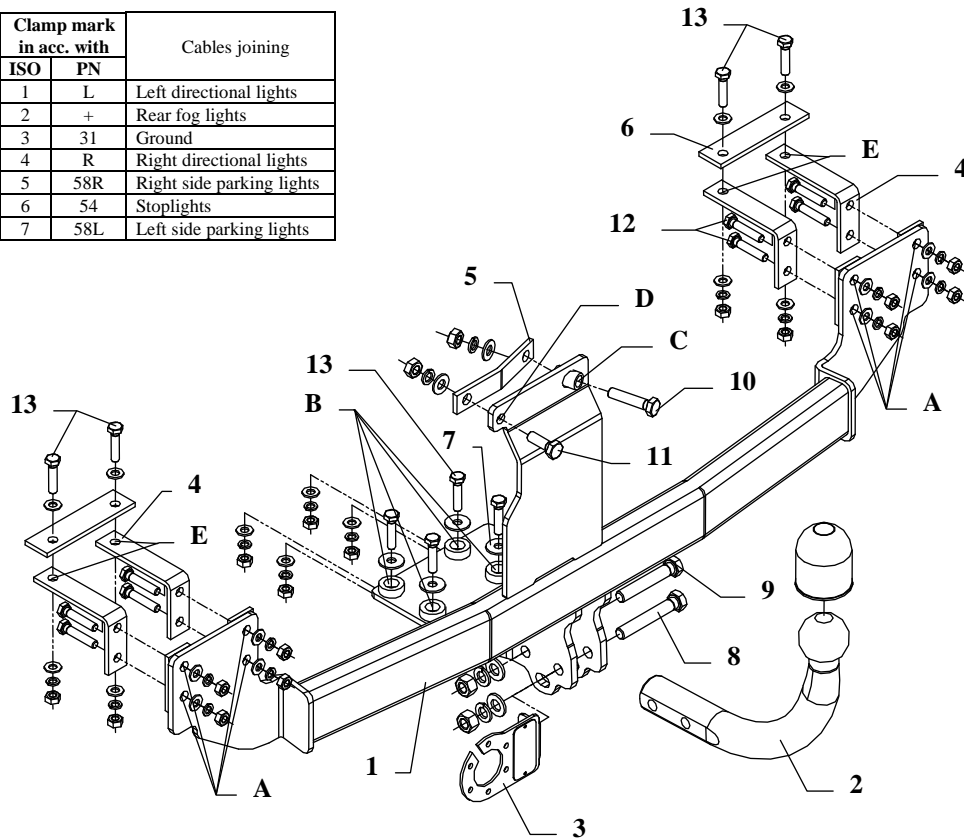

This towing hitch is designed to assembly in following cars: **ALFA ROMEO 145, 3 doors, except 2.0L 114KW**, produced since 1994 till 2001, catalogue no. **AL33** and is prepared to tow trailers max total weight **1400 kg** and max vertical load **50 kg**.

From manufacturer

Thank you for buying our product. Their reliability has been confirmed in many tests. Reliability of towing hitch depends also on correct assembly and correct exploitation. For this reasons we kindly ask to read carefully this instruction and apply to hints.

The towing hitch should be install in points described by a car producer.

The instruction of the assembly

1. Disassemble the bumper, remove filling foam from body.
2. From trunk, remove carpet and unclasp plastic cover of rear body part.
3. Put main bar of towing hitch (pos. 1) to rear part of car and chassis in that way, so towing hitch are in axis of car, next fix it using clamps (very precisely). Through holes (pos. A) and (pos. B) drill straight through holes $\varnothing 9\text{mm}$, and through holes (pos. C) and (pos. D) drill holes $\varnothing 10\text{mm}$. In this way prepared towing hitch fix with bolts M8x35mm (pos. 13), M10x30mm (pos. 11) and M10x45mm (pos. 10) using washers (pos. 4) and (pos. 5) as shown in the drawing.
4. Through holes (pos. E) in elements (pos. 4) drill straight holes $\varnothing 9\text{mm}$, next fix with fish-plates (pos. 6).
5. Tighten all bolts according to the torque shown in the table.
6. Clasp foam filling, before cut his fragments in points where clash with towing hitch .
7. Assemble bumper after cut out according with fig. 2.

Fig. 2

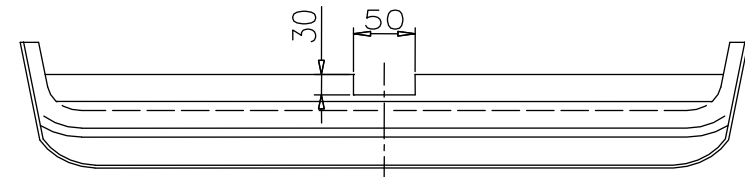

8. Fix tow ball (pos. 2) using bolt M12x75mm (pos. 8) and M12x70mm (pos. 9). With bolt M12x75mm fix also a socket plate (pos. 3). See figure 1.
9. Tighten all bolts according to the torque shown in the table.
10. Connect electric wires of 7-poles socket according to the instruction of the car. (Recommend to make at authorized service station)
11. Complete paint layer damaged during installation.

Torque settings for nuts and bolts (8,8):	
M 8 - 25 Nm	M 10 - 55 Nm
M 12 - 85 Nm	M 14 - 135 Nm

NOTE

After install the towing hitch you should get adequate note in registration book (at authorised service station).The car should be equipped with:

- Indicators
- Tow mirrors

After 1000km check all fixes. The ball of towing hitch must be always kept clear and conserve with a grease.

Towing hitch equipment:

Pos. 1 Main bar PCS.: 1	Pos. 6 Fish-plate PCS.: 2	Pos. 12 Bolt 8,8 B M8x40mm PCS.: 8	Pos. 18 Plain washer ø10mm PCS.: 2
	Pos. 7 Washer ø25xø9x2mm PCS.: 4	Pos. 13 Bolt 8,8 B M8x35mm PCS.: 8	Pos. 19 Plain washer ø8mm PCS.: 20
Pos. 2 Tow ball PCS.: 1	Pos. 8 Bolt 8,8 B M12x75mm PCS.: 1	Pos. 14 Nut 8 B M12 PCS.: 2	Pos. 20 Spring washer ø12mm PCS.: 2
Pos. 3 Socket plate PCS.: 1	Pos. 9 Bolt 8,8 B M12x70mm PCS.: 1	Pos. 15 Nut 8 B M10 PCS.: 2	Pos. 21 Spring washer ø10mm PCS.: 2
Pos. 4 Fish-plate PCS.: 4	Pos. 10 Bolt 8,8 B M10x45mm PCS.: 1	Pos. 16 Nut 8 B M8 PCS.: 16	Pos. 22 Spring washer ø8mm PCS.: 16
Pos. 5 Fish-plate PCS.: 1	Pos. 11 Bolt 8,8 B M10x30mm PCS.: 1	Pos. 17 Plain washer ø12mm PCS.: 2	Pos. 23 Ball cover PCS.: 1



PPUH AUTO-HAK S.J.

Produkcja Zaczepów Kulowych
Henryk & Zbigniew Nejman
76-200 SŁUPSK ul. Słoneczna 16K
tel/fax (059) 8-414-414; 8-414-413
E-mail: office@autohak.com.pl
www. autohak.com.pl

Towing hitch (without electrical set)

Class: **A50-X** Cat. no. **AL33**

Designed for:

Manufacturer: **ALFA ROMEO**

Model: **145**

Type: **3 doors, except 2.0L 114KW**

produced since 1994 till 2001

Technical data:

D-value: 7,73 kg

maximum trailer weight: **1400 kg**

maximum vertical cup load: **50 kg**

Approval number according to Directive 94/20/EC: **e20*94/20*0385*00**

Foreword

This towing hitch is design according to rules of safety traffic regulations. The towing hitch is a safety component and must be installed only by qualified personnel. Any alteration or conversion to the towinh hitch is prohibited and would lead to cancellation of design certification. Remove insulating compound and underseal from vehicle (if present) in the area of the matting surfaces of the towing hitch.

The vehicle manufacturer's specifications regarding trailer load and max. vertical cup load are decisive for driving, and values for the towing hitch cannot be exceeded.

D-value formula:

$$\frac{\text{Max trailer weight [kg]} \times \text{Max vehicle weight [kg]}}{\text{Max trailer weight [kg]} + \text{Max vehicle weight [kg]}} \times \frac{9,81}{1000} = D \text{ [kN]}$$