

FITTING INSTRUCTION

Clamp mark in acc. with		Cables joining
ISO	PN	
1	L	Left directional lights
2	+	Rear fog lights
3	31	Ground
4	R	Right directional lights
5	58R	Right side parking lights
6	54	Stoptlights
7	58L	Left side parking lights

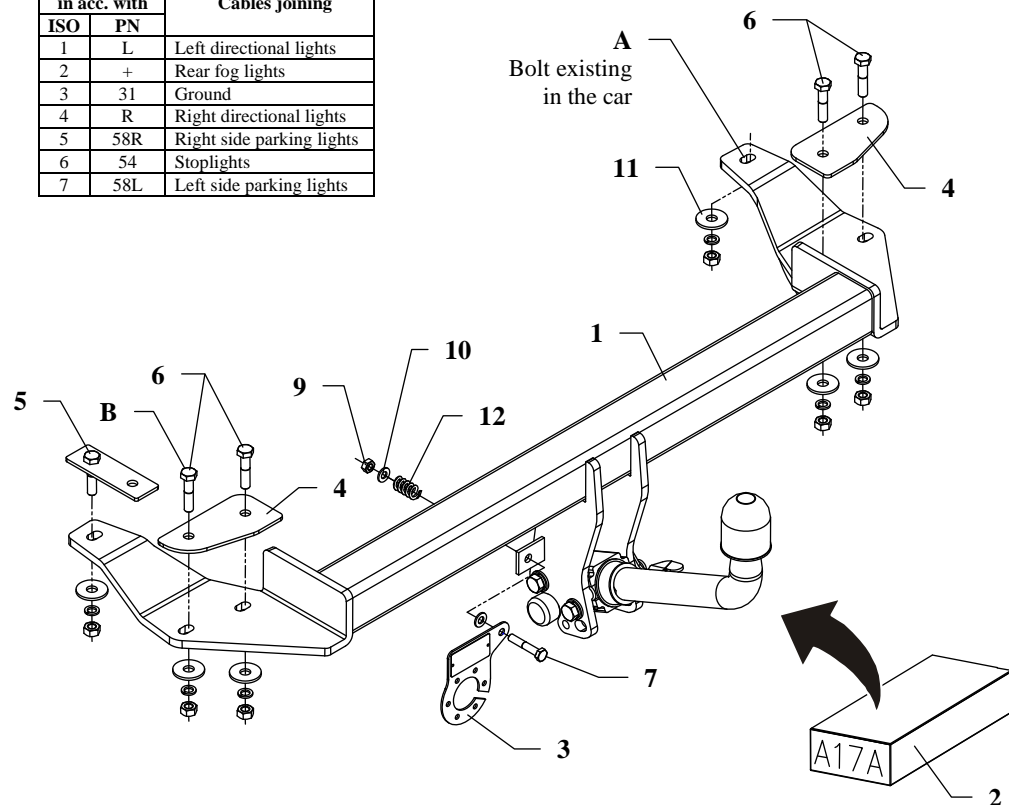

This towbar is designed to assembly in following cars:
AUDI A8, 4 doors, QUATTRO (S8), produced since 06.1994 till 09.2002,
 catalogue no. **A17A** and is prepared to tow trailers max total weight **2350 kg** and max vertical load **75 kg**.

From manufacturer

Thank you for buying our product. Their reliability has been confirmed in many tests. Reliability of towbar depends also on correct assembly and right operation. For this reasons we kindly ask to read carefully this instruction and apply to hints.

The towbar should be install in points described by a car producer.

The instruction of the assembly

1. Disassemble the bumper.
2. Disassemble original towing eye from the right, rear side of the car (not used any more).
3. Disassemble rear handle of the muffer fastener.
4. Disassemble handle of bumper fastener (left side), put bolt on the jib (pos. 5) (place it in original hole as existing bolt (pos. A) on the right side).
5. Put main bar of the towbar (pos. 1) in this way, so towbar holes agree with holes in chassis and fix as show on the figure (use washers pos. 11).
6. Fix bracket of muffer fastener (before install remove bolt from it), this will make possible to fix above mentioned to bolt (pos. B).
7. Reinstall the bumper.
8. Fix body of the automat and place tow-ball according to supplied instruction.
9. Fix the socket plate (pos. 3) as shown on the drawing.
10. Tighten all bolts according to the torque shown in the table.
11. Connect electric wires of 7-poles socket according to the instruction of the car. (Recommend to make at authorized service station).
12. Complete paint layer damaged during installation.

Torque settings for nuts and bolts (8,8):	
M 8 - 25 Nm	M 10 - 55 Nm
M 12 - 85 Nm	M 14 - 135 Nm











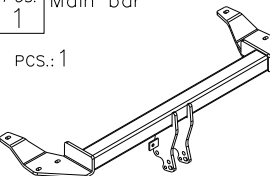
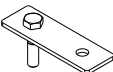

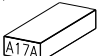
NOTE

After install the towbar you should get adequate note in registration book (at authorised service station).The car should be equipped with:

- Indicators
- Tow mirrors

After 1000km check all bolts and nuts. The ball of towbar must be always kept clear and conserve with a grease.

Towbar accessories:

Pos. 1	Main bar  PCS.: 1	Pos. 5	Fish-plate with bolt  PCS.: 1	Pos. 10	Plain washer ø8mm  PCS.: 2
Pos. 2	Tow ball (mounting set)  PCS.: 1	Pos. 6	Bolt 8,8 B M10x45mm  PCS.: 4	Pos. 11	Washer ø30xø10,5x2,5mm  PCS.: 6
Pos. 3	Socket plate  PCS.: 1	Pos. 7	Bolt 8,8 B M8x45mm  PCS.: 1	Pos. 12	Spring washer 6 ø 10,2 mm  PCS.: 1
Pos. 4	Fish-plate  PCS.: 2	Pos. 8	Nut 8 B M10  PCS.: 6	Pos. 13	Spring  PCS.: 1
		Pos. 9	Nut 8 B M8  PCS.: 1		



PPUH AUTO-HAK S.J.

Produkcja Zaczepów Kulowych
Henryk & Zbigniew Nejman
76-200 SŁUPSK ul. Słoneczna 16K
tel/fax (059) 8-414-414; 8-414-413
E-mail: office@autohak.com.pl
www.autohak.com.pl

Towing hitch (without electrical set)

Class: **A50-X** Cat. no. **A17A**

Designed for:

Manufacturer: **AUDI**

Model: **A8**

Type: **4 doors QUATTRO (S8)**

produced since 06.1994 till 09.2002

Technical data:

D-value: 12,5 kN

maximum trailer weight: **2350 kg**

maximum vertical cup load: **75 kg**

Approval number acc. to regulations EKG/ONZ 55.01: E20-55R-01 1797

Foreword

This towbar is designed according to rules of safety traffic regulations. The towing hitch is a safety component and can be install only by qualified personnel. Any alteration or conversion of the towing hitch is prohibited and would lead to cancellation of design certification. Remove insulating compound and underseal from vehicle (if present) in the area of the matting surfaces of the towing hitch. The vehicle manufacturer's specifications regarding trailer load and max. vertical cup load are decisive for driving whereat values for the towing hitch cannot be exceeded.

D-value formula:

$$\frac{\text{Max trailer weight [kg]} \times \text{Max vehicle weight [kg]}}{\text{Max trailer weight [kg]} + \text{Max vehicle weight [kg]}} \times \frac{9,81}{1000} = D \text{ [kN]}$$