

FITTING INSTRUCTION

Clamp mark in acc. with		Cables joining
ISO	PN	
1	L	Left directional lights
2	+	Rear fog lights
3	31	Ground
4	R	Right directional lights
5	58R	Right side parking lights
6	54	Stoptlights
7	58L	Left side parking lights

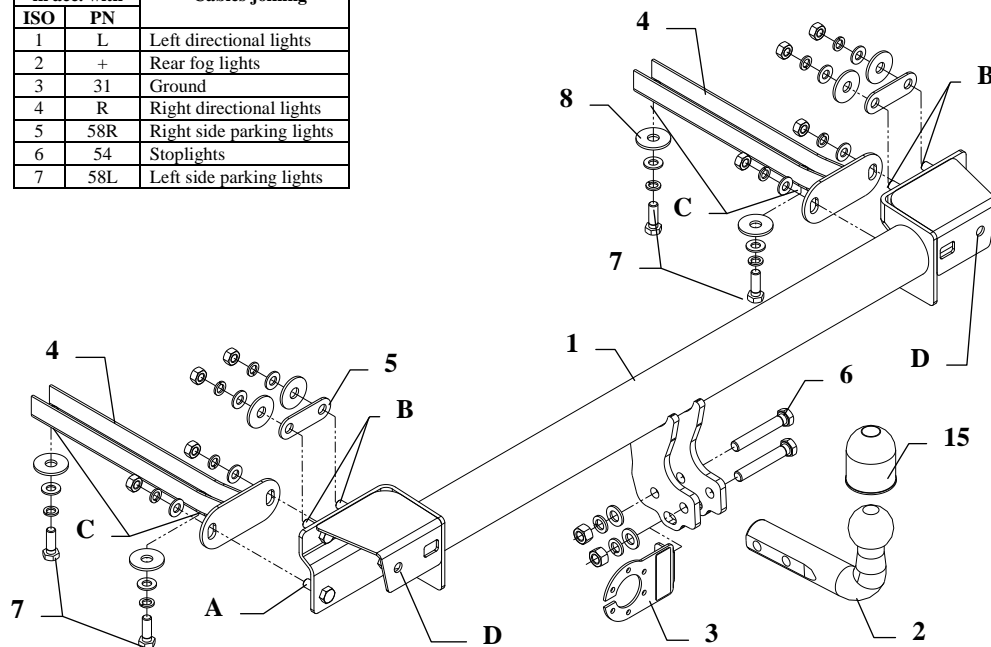

This towing hitch is designed to assembly in following cars:
BMW 3 Series E30, 4 doors, Coupe, produced since 10.1982 till 09.1990,
BMW 3 Series E30 Touring, Estate, except M Package, produced since 09.1987 till 08.1994, catalogue no. **B01** and is prepared to tow trailers max total weight **1400 kg** and max vertical load **75 kg**.

From manufacturer

Thank you for buying our product. Their reliability has been confirmed in many tests. Reliability of towing hitch depends also on correct assembly and right operation. For this reasons we kindly ask to read carefully this instruction and apply to hints.

The towing hitch should be install in points described by a car producer.

The instruction of the assembly

- For the purpose of installings towing hitch one ought to disassemble the bumper
 - for vehicles produced since 08.1982 till 08.1987 untwist industrial handles fastening (Attention: the narrow bumper).
 - for vehicles produced since 08.1987 till 12.1993 unscrew industrial handles fastening, the internal fulfillment of the bumper and the external elastic protection (Attention: the wide bumper).
- To back piece apply the main bar of the towing hitch (pos. 1) and mark points (pos. A i B). In marked points drill holes $\varnothing 11\text{mm}$.
- Among well-made holes are situated perforated holes $\varnothing 46\text{mm}$ (on the left and right side of the piece), which one should perforate.
- Side brackets of the towing hitch (pos. 4) one ought to slip through perforated holes into chassis member and across existing holes of chassis members and holes (pos. C) twist loosely with bolts M10x30mm (pos. 7).
- Fix the main bar of the towing hitch (pos. 1) to the bumper through holes (pos. D)
 - for vehicles produced since 08.1982 till 08.1987 directly by means previously disassembled nuts.
 - for vehicles produced since 08.1987 till 12.1993 - first cut out fragment of a bumper in it's axis (width 80mm and depth 40mm). Next apply the main bar of the towing hitch (pos. 1) in the central part of the bumper and mark points (pos. D), then make holes in the bumper ($\varnothing 9\text{mm}$) and fix the main bar of the towing hitch (pos. 1) and put previously disassembled elastic protection.
- So prepared towing hitch apply to the back piece and fix with side brackets (pos. 4) through holes (pos. A) along with fish-plates (pos. 5) through holes (pos. B) using nuts M10.
- Fix tow-ball (pos. 2) and socket plate (pos. 3) by bolts M12x75mm (pos. 6) from accessories.
- Tighten all bolts according to the torque shown in the table.
- Connect electric wires of 7-poles socket according to the instruction of the car. (Recommend to make at authorized service station).
- Complete paint layer damaged during installation.

Torque settings for nuts and bolts (8,8):

M6 - 11 Nm	M8 - 25 Nm	M10 - 50 Nm
M12 - 87 Nm	M14 - 138 Nm	M16 - 210 Nm











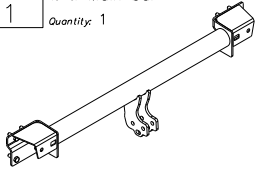

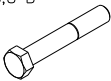

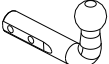
NOTE

After install the towing hitch you should get adequate note in registration book (at authorised service station).The car should be equipped with:

- Indicators
- Tow mirrors

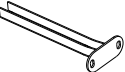
After 1000km of exploitation check all bolts and nuts. The ball of towing hitch must be always kept clear and conserve with a grease.

Towing hitch accessories:

Pos. 1 Name: Main bar Quantity: 1 	Pos. 5 Name: Fish-plate Quantity: 2 Dim.: 77x26x3mm 	Pos. 10 Name: Nut 8 B Quantity: 8 Dim.: M10 
	Pos. 6 Name: Bolt 8,8 B Quantity: 2 Dim.: M12x75mm 	Pos. 11 Name: Plain washer Quantity: 2 Dim.: Ø 13 mm 
Pos. 2 Name: Tow ball Quantity: 1 	Pos. 7 Name: Bolt 8,8 B Quantity: 4 Dim.: M10x30mm 	Pos. 12 Name: Plain washer Quantity: 12 Dim.: Ø 10,5 mm 
Pos. 3 Name: Socket plate Quantity: 1 	Pos. 8 Name: Washer Quantity: 8 Dim.: Ø35xØ12x3mm 	Pos. 13 Name: Spring washer Quantity: 2 Dim.: Ø 12,2 mm 
Pos. 4 Name: Side bracket Quantity: 2 	Pos. 9 Name: Nut 8 B Quantity: 2 Dim.: M12 	Pos. 14 Name: Spring washer Quantity: 12 Dim.: Ø 10,2 mm 
		Pos. 15 Name: Ball cover Quantity: 1 



PPUH AUTO-HAK Sp.J.

Produkcja Zaczepów Kulowych
Henryk & Zbigniew Nejman
76-200 SŁUPSK ul. Słoneczna 16K
tel/fax (059) 8-414-414; 8-414-413
e-mail: office@autohak.com.pl
www.autohak.com.pl

Towing hitch (without electrical set)

Class: **A50-X** Cat. no. **B01**

Designed for:

Manufacturer: **BMW**

Model: **SERIES 3 (E30)**

Type: **4doors, COUPE**

produced since 10.1982 till 09.1990

Model: **SERIES 3 (E30) Touring**

Type: **ESTATE, except M Package**

produced since 09.1987 till 08.1994

Technical data:

D-value: 8,0 kN

maximum trailer weight: **1400 kg**

maximum vertical cup load: **75 kg**

Approval number acc. to regulations EKG/ONZ 55.01: **E20-55R-01 4718**

Foreword

This towing hitch is designed according to rules of safety traffic regulations. The towing hitch is a safety component and can be install only by qualified personnel. Any alteration or conversion of the towing hitch is prohibited and would lead to cancellation of design certification. Remove insulating compound and underseal from vehicle (if present) in the area of the matting surfaces of the towing hitch. The vehicle manufacturer's specifications regarding trailer load and max. vertical cup load are decisive for driving, and values for the towing hitch cannot be exceeded.

D-value formula:

$$\frac{\text{Max trailer weight [kg]} \times \text{Max vehicle weight [kg]}}{\text{Max trailer weight [kg]} + \text{Max vehicle weight [kg]}} \times \frac{9,81}{1000} = D \text{ [kN]}$$