

FITTING INSTRUCTION

Clamp mark in acc. with		Cables joining
ISO	PN	
1	L	Left directional lights
2	+	Rear fog lights
3	31	Ground
4	R	Right directional lights
5	58R	Right side parking lights
6	54	Stoptlights
7	58L	Left side parking lights

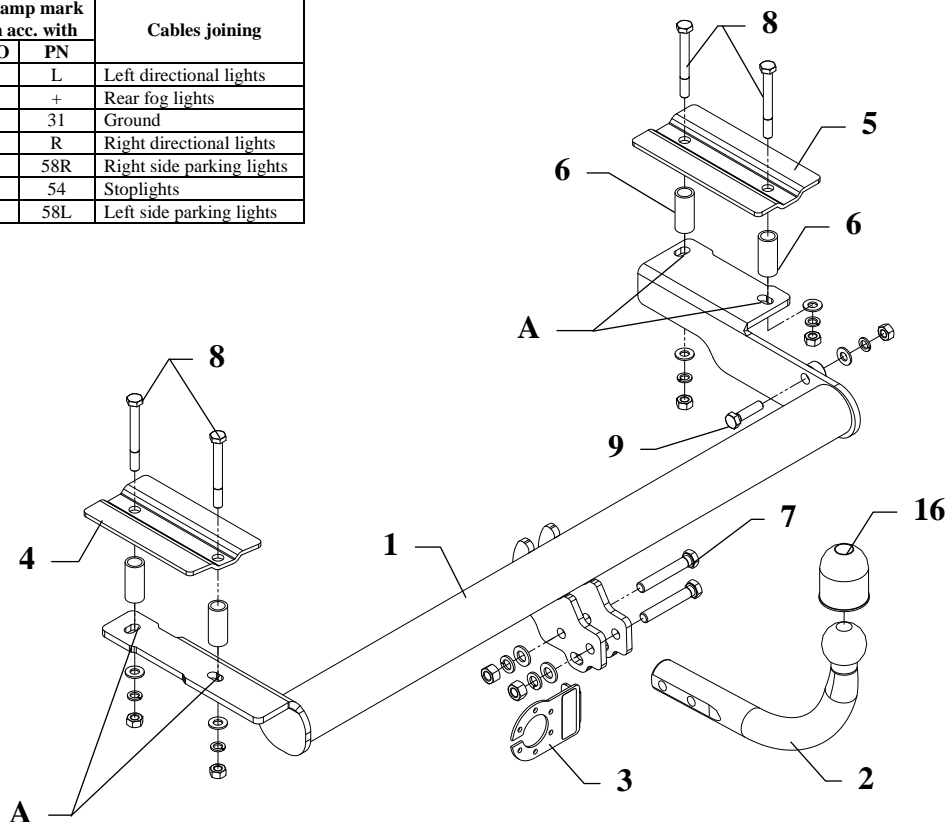

This towbar is designed to assembly in following cars:
FORD ESCORT Turning, ESTATE, produced since 10.1990 till 02.1999, catalogue no. **C22** and is prepared to tow trailers max total weight **1250 kg** and max vertical load **50 kg**.

From manufacturer

Thank you for buying our product. Their reliability has been confirmed in many tests. Reliability of towbar depends also on correct assembly and right operation. For this reasons we kindly ask to read carefully this instruction and apply to hints.

The towbar should be install in points described by a car producer.

The instruction of the assembly

1. It is not necessary to reassemble the bumper.
2. Find original signed places inside the boot on the left and right side, then drill $\varnothing 24\text{mm}$.
3. Slide the sleeves $L=48\text{mm}$ and position the fish-plates (pos. 4 and 5).
4. Cut the bottom part of the bumper – $70 \times 20\text{mm}$.
5. Position the main bar of towbar (pos. 1) and fix it through the holes (pos. A), sleeves and the fish-plates (pos. 4 and 5) using $M10 \times 90\text{mm}$ (pos. 8).
6. Fix through the holes (pos. B) and original towing eye on the right side using $M10 \times 40\text{mm}$ (pos. 9).
7. Tighten all nuts and bolts according to the torque shown in the table.
8. Position the ball of towbar (pos. 2) together with socket plate (pos. 3) and fix it with $M12 \times 75\text{mm}$ (pos. 7) from the towbar accessories.
9. Connect the electric wires according to the instructions of the car.
10. Complete the paint cover of towbar (during the mounting paint cover could be destroyed).

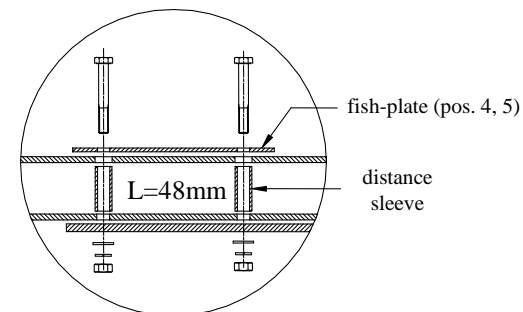

Torque settings for nuts and bolts (8,8):	
M 8 - 25 Nm	M 10 - 55 Nm
M 12 - 85 Nm	M 14 - 135 Nm

NOTE

After install the towbar you should get adequate note in registration book (at authorised service station).The car should be equipped with:

- Indicators
- Tow mirrors

After 1000km check all screws. The ball of towbar must be always kept clear and conserve with a grease.

Towbar accessories:

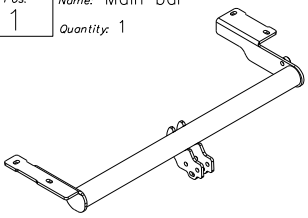
Pos. 1	Name: Main bar Quantity: 1	Pos. 5	Name: Right fish-plate Quantity: 1 Dim.: 200x100x5mm	Pos. 11	Name: Nut 8 B Quantity: 5 Dim.: M10
		Pos. 6	Name: Distance sleeve Quantity: 4 Dim.: Ø21,3x2,65mm, L=48mm	Pos. 12	Name: Plain washer Quantity: 2 Dim.: Ø 13 mm
Pos. 2	Name: Tow ball Quantity: 1	Pos. 7	Name: Bolt 8,8 B Quantity: 2 Dim.: M12x75mm	Pos. 13	Name: Plain washer Quantity: 5 Dim.: Ø 10,5 mm
Pos. 3	Name: Socket plate Quantity: 1	Pos. 8	Name: Bolt 8,8 B Quantity: 4 Dim.: M10x90mm	Pos. 14	Name: Spring washer Quantity: 2 Dim.: Ø 12,2 mm
Pos. 4	Name: Left fish-plate Quantity: 1 Dim.: 184x100x5mm	Pos. 9	Name: Bolt 8,8 B Quantity: 1 Dim.: M10x40mm	Pos. 15	Name: Spring washer Quantity: 5 Dim.: Ø 10,2 mm
		Pos. 10	Name: Nut 8 B Quantity: 2 Dim.: M12	Pos. 16	Name: Ball cover Quantity: 1



PPUH AUTO-HAK S. J.

Produkcja Haków Holowniczych
Henryk & Zbigniew Nejman
76-200 SŁUPSK ul. Słoneczna 16K
tel/fax (059) 8-414-414; 8-414-413
E-mail: office@autohak.com.pl
www.autohak.com.pl

Towing hitch (without electrical set)

Class: **A50-X** Cat. no. **C22**

Designed for:

Manufacturer: **FORD**

Model: **ESCORT Turning**

Type: **ESTATE**

produced since 10.1990 till 02.1999

Technical data:

D-value: 7,12 kN

maximum trailer weight: **1250 kg**

maximum vertical cup load: **50 kg**

Approval number acc. to regulations EKG/ONZ 55.01: E20-55R-01 0894

Foreword

This towbar is designed according to rules of safety traffic regulations. The towing hitch is a safety component and can be install only by qualified personnel. Any alteration or conversion of the towing hitch is prohibited and would lead to cancellation of design certification. Remove insulating compound and underseal from vehicle (if present) in the area of the matting surfaces of the towing hitch.

The vehicle manufacturer's specifications regarding trailer load and max. vertical cup load are decisive for driving, and values for the towing hitch cannot be exceeded.

D-value formula:

$$\frac{\text{Max trailer weight [kg]} \times \text{Max vehicle weight [kg]}}{\text{Max trailer weight [kg]} + \text{Max vehicle weight [kg]}} \times \frac{9,81}{1000} = D \text{ [kN]}$$