

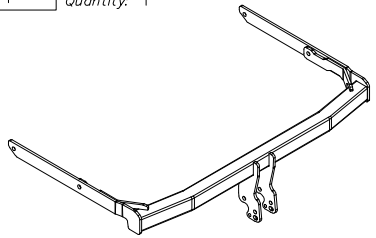

## Towbar accessories:

|   |                                   |   |   |
|---|-----------------------------------|---|---|
| Pos.<br>1   | Name: Main bar<br>Quantity: 1     | Pos.<br>4   | Name: Washer<br>Quantity: 4<br>Dim. : $\phi 42 \times \phi 12 \times 3 \text{mm}$ |
|  |                                   | Pos.<br>5   | Name: Bolt 8,8 B<br>Quantity: 4<br>Dim. : M10x40mm                                |
|   |                                   | Pos.<br>6   | Name: Plain washer<br>Quantity: 4<br>Dim. : $\phi 10,5 \text{ mm}$                |
| Pos.<br>2   | Name: Tow ball<br>Quantity: 1     | Pos.<br>7   | Name: Spring washer<br>Quantity: 4<br>Dim. : $\phi 10,2 \text{ mm}$               |
|  |                                   |  |   |
| Pos.<br>3   | Name: Socket plate<br>Quantity: 1 |  |   |

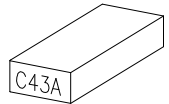

## PPUH AUTO-HAK S.J.

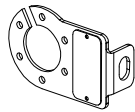
Produkcja Zaczepów Kulowych  
Henryk & Zbigniew Nejman  
76-200 SŁUPSK ul. Słoneczna 16K  
tel/fax (059) 8-414-414; 8-414-413  
E-mail: office@autohak.com.pl  
www. autohak.com.pl

### Towing hitch (without electrical set)

Class: **A50-X** Cat. no. **C43A**

Designed for:

Manufacturer: **FORD**

Model: **FUSION**

Type: **5 doors, VAN**

produced since 09.2002 till 09.2005 and 10.2005

Technical data:

**D-value: 5,70 kN**

maximum trailer weight: **900 kg**

maximum vertical cup load: **50 kg**

Approval number according to Directive 94/20/EC: **e20\*94/20\*0927\*00**

### Foreword

This towbar is designed according to rules of safety traffic regulations. The towing hitch is a safety component and must be installed only by qualified personnel. Any alteration or conversion to the towing hitch is prohibited and would lead to cancellation of design certification. Remove insulating compound and underseal from vehicle (if present) in the area of the matting surfaces of the towing hitch.

The vehicle manufacturer's specifications regarding trailer load and max. vertical cup load are decisive for driving, and values for the towing hitch cannot be exceeded.

*D-value formula:*

$$\frac{\text{Max trailer weight [kg]} \times \text{Max vehicle weight [kg]}}{\text{Max trailer weight [kg]} + \text{Max vehicle weight [kg]}} \times \frac{9,81}{1000} = D \text{ [kN]}$$

## FITTING INSTRUCTION

| Clamp mark in acc. with |     | Cables joining            |
|-------------------------|-----|---------------------------|
| ISO                     | PN  |                           |
| 1                       | L   | Left directional lights   |
| 2                       | +   | Rear fog lights           |
| 3                       | 31  | Ground                    |
| 4                       | R   | Right directional lights  |
| 5                       | 58R | Right side parking lights |
| 6                       | 54  | Stoplights                |
| 7                       | 58L | Left side parking lights  |

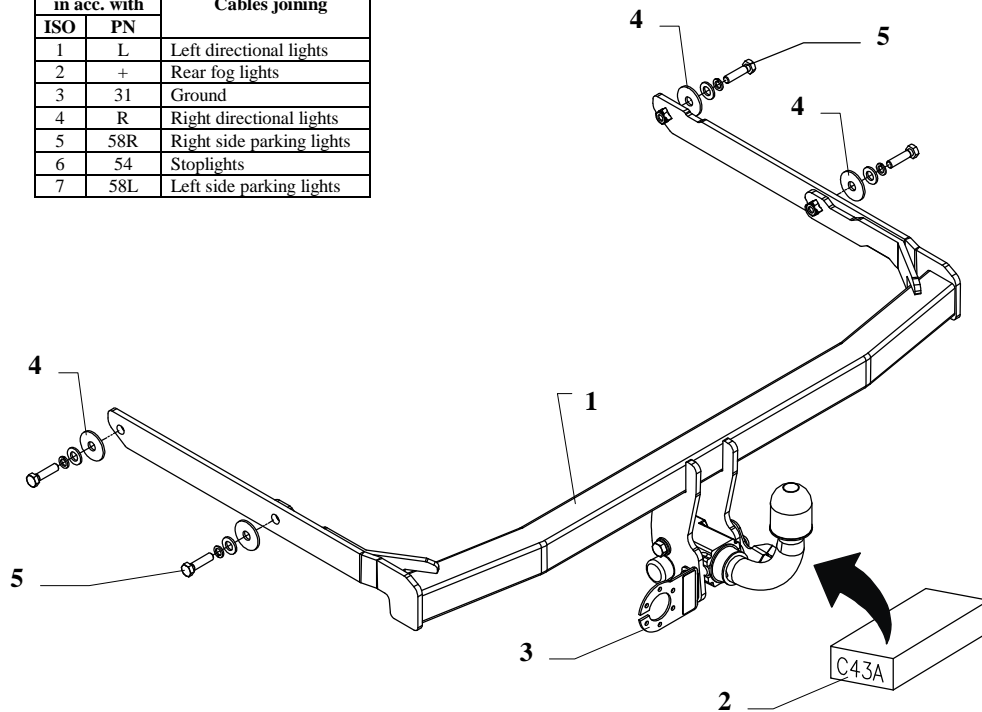

### The instruction of the assembly

1. Disassemble the bumper.
2. Slip main part of the towbar (pos. 1) to chassis members and fix it with bolts M10x40mm (pos. 5) from accessories (use flat washers – pos. 4).
3. Reassemble the bumper.
4. Fix body of the automat and place tow-ball according to supplied instruction. Note! Remember to place socket plate (pos. 3) as shown on the drawing 1.
5. Fix all bolts according to the torque shown in the table.
6. Connect electric wires according to the instruction of the car. (Recommend to make at authorized service station)
7. Supplement the paint coating damaged during assembly.

Torque settings for nuts and bolts (8,8):

|             |       |             |        |
|-------------|-------|-------------|--------|
| <b>M 8</b>  | 25 Nm | <b>M 10</b> | 55 Nm  |
| <b>M 12</b> | 85 Nm | <b>M 14</b> | 135 Nm |

This towbar is designed to assembly in following car:  
**FORD FUSION, 5 doors, VAN**, produced since 09.2002 till 09.2005 and since 10.2005, catalogue no. **C43A** and is prepared to tow trailers max total weight **900 kg** and max vertical load **50 kg**.

#### *From manufacturer*

Thank you for buying our product. Their reliability has been confirmed in many tests. Reliability of towbar depends also on correct assembly and right operation. For this reasons we kindly ask to read carefully this instruction and apply to hints.

*The towbar should be install in points described by a car producer..*

#### NOTE

After install the towbar you should get adequate note in registration book (at authorised service station).The car should be equipped with:

- Indicators
- Tow mirrors

After 1000km of exploitation check all bolts and nuts. The ball of towbar must be always kept clear and conserve with a grease.