

## FITTING INSTRUCTION

Clamp mark in acc. with		Cables joining
ISO	PN	
1	L	Left directional lights
2	+	Rear fog lights
3	31	Ground
4	R	Right directional lights
5	58R	Right side parking lights
6	54	Stoplights
7	58L	Left side parking lights

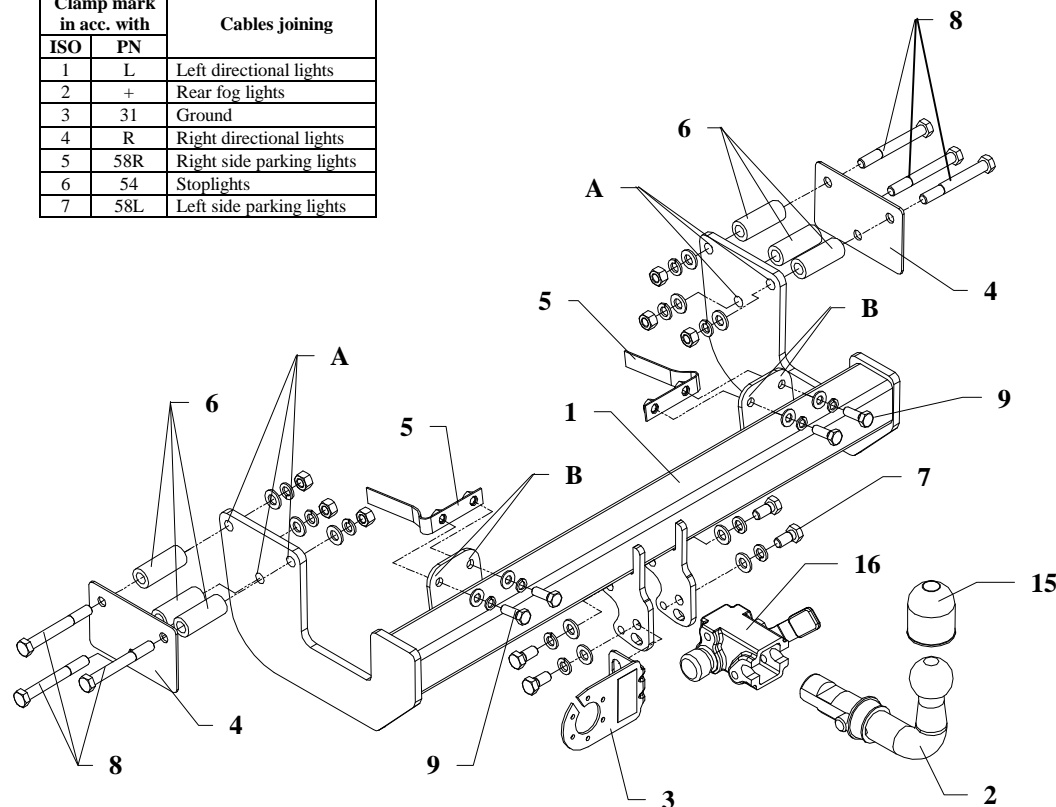

Fig.1

This towbar is designed to assembly in following car:  
**MERCEDES VITO (Class V)**, produced since 1996 till 06.2003,  
 catalogue no. **D11A** and is prepared to tow trailers max total weight  
**2000 kg** and max vertical load **100 kg**.

### *From manufacturer*

Thank you for buying our product. Their reliability has been confirmed in many tests. Reliability of towbar depends also on correct assembly and right operation. For this reasons we kindly ask to read carefully this instruction and apply to hints.

*The towbar should be install in points described by a car producer.*

## The instruction of the assembly

1. Disassemble the rear bumper.
2. Position three distance sleeves pos. 6 (L=62) per each side to holes on the left and right side of chassis members.
3. Put main bar of the towbar (pos. 1) to chassis members as shown in the drawing no. 1 and screw using bolts M12x100mm (pos. 8) through holes (pos. 6) and with rectangular plates (pos. 4) from accessories.
4. To existing holes in rear side of car slip nuts M10 on the jib (pos. 5) and screw through holes (pos. B) using bolts M10x30mm (pos. 9).
5. Install the bumper after cut out the fragment in its axis (width 80mm, depth 30mm).
6. Fix body of the automat (pos. 16) and the socket plate (pos. 3) using bolts M12x25mm (pos. 7) from accessories. Place tow-ball (pos. 2) according to supplied instruction.
7. Tighten all bolts according to the torque shown in the table.
8. Connect electric wires of 7-poles socket according to the instruction of the car. (Recommend to make at authorized service station)
9. Complete the paint coating damaged during installation.

Torque settings for nuts and bolts (8,8):

<b>M 8</b>	25 Nm	<b>M 10</b>	55 Nm
<b>M 12</b>	85 Nm	<b>M 14</b>	135 Nm











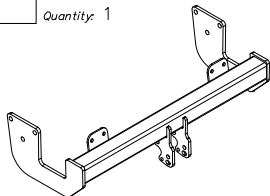

### NOTE

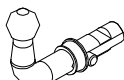
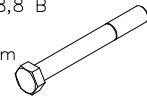
After install the towbar you should get adequate note in registration book (at authorised service station).The car should be equipped with:

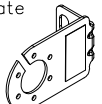
- Indicators
- Tow mirrors

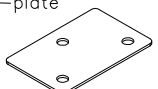
After 1000km check all bolts and nuts. The ball of towbar must be always kept clear and conserve with a grease.

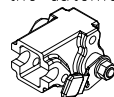
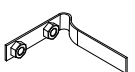
## Towbar accessories:

Pos. 1 Name: Main bar Quantity: 1 	Pos. 6 Name: Distance sleeve Quantity: 6 	Pos. 12 Name: Plain washer Quantity: 4 Dim.: Ø10,5 mm 
	Pos. 7 Name: Bolt 8,8 B Quantity: 4 Dim.: M12x25mm 	Pos. 13 Name: Spring washer Quantity: 10 Dim.: Ø12,2 mm 
Pos. 2 Name: Tow ball Quantity: 1 	Pos. 8 Name: Bolt 8,8 B Quantity: 6 Dim.: M12x100mm 	Pos. 14 Name: Spring washer Quantity: 4 Dim.: Ø10,2 mm 
Pos. 3 Name: Socket plate Quantity: 1 	Pos. 9 Name: Bolt 8,8 B Quantity: 4 Dim.: M10x30mm 	Pos. 15 Name: Ball cover Quantity: 1 
Pos. 4 Name: Fish-plate Quantity: 2 	Pos. 10 Name: Nut 8 B Quantity: 6 Dim.: M12 	Pos. 16 Name: Body of the automat Quantity: 1 
Pos. 5 Name: Jib with nuts Quantity: 2 	Pos. 11 Name: Plain washer Quantity: 10 Dim.: Ø13 mm 	Pos. 17 Name: Body plug Quantity: 1 



**PPUH AUTO-HAK S.J.**

Produkcja Haków Holowniczych  
Henryk & Zbigniew Nejman  
76-200 SŁUPSK ul. Słoneczna 16K  
tel/fax (059) 8-414-414; 8-414-413  
E-mail: office@autohak.com.pl  
www. autohak.com.pl

## Towing hitch (without electrical set)

Class: **A50-X** Cat. no. **D11A**

Designed for:

Manufacturer: **MERCEDES**

Model: **VITO**

Type: **Class V**

produced since 1996 till 06.2003

Technical data:

**D-value: 11,27 kN**

maximum trailer weight: **2000 kg**

maximum vertical cup load: **100 kg**

**Approval number according to Directive 94/20/EC: e20\*94/20\*1034\*00**

## Foreword

This towbar is designed according to rules of safety traffic regulations. The towing hitch is a safety component and must be installed only by qualified personnel. Any alteration or conversion to the towinh hitch is prohibited and would lead to cancellation of design certification. Remove insulating compound and underseal from vehicle (if present) in the area of the matting surfaces of the towing hitch.

The vehicle manufacturer's specifications regarding trailer load and max. vertical cup load are decisive for driving, and values for the towing hitch must not be exceeded.

*D-value formula:*

$$\frac{\text{Max trailer weight [kg]} \times \text{Max vehicle weight [kg]}}{\text{Max trailer weight [kg]} + \text{Max vehicle weight [kg]}} \times \frac{9,81}{1000} = D \text{ [kN]}$$