

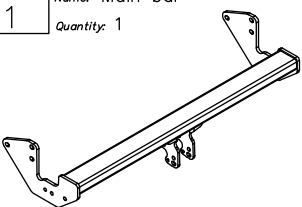

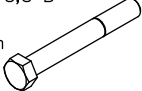









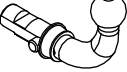

Towbar accessories:

Pos. 1 Name: Main bar Quantity: 1 	Pos. 6 Name: Bolt 8,8 B Quantity: 6 Dim.: M12x90mm 	Pos. 12 Name: Plain washer Quantity: 10 Dim.: Ø 10,5 mm 
	Pos. 7 Name: Bolt 8,8 B Quantity: 4 Dim.: M12x25mm 	Pos. 13 Name: Spring washer Quantity: 10 Dim.: Ø 12,2 mm 
Pos. 2 Name: Tow ball Quantity: 1 	Pos. 8 Name: Bolt 8,8 B Quantity: 10 Dim.: M10x35mm 	Pos. 14 Name: Spring washer Quantity: 10 Dim.: Ø 10,2 mm 
Pos. 3 Name: Socket plate Quantity: 1 	Pos. 9 Name: Nut 8 B Quantity: 6 Dim.: M12 	Pos. 15 Name: Ball cover Quantity: 1 
Pos. 4 Name: Right bracket Quantity: 1 Dim.: 130x75x52mm 	Pos. 10 Name: Nut 8 B Quantity: 6 Dim.: M10 	Pos. 16 Name: Body of the automat Quantity: 1 
Pos. 5 Name: Left bracket Quantity: 1 Dim.: 130x75x52mm 	Pos. 11 Name: Plain washer Quantity: 10 Dim.: Ø 13 mm 	Pos. 17 Name: Body plug Quantity: 1 

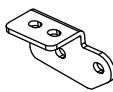

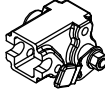
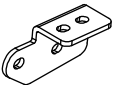
PPUH AUTO-HAK Sp.J.

Produkcja Zaczepów Kulowych
Henryk & Zbigniew Nejman
76-200 SŁUPSK ul. Słoneczna 16K
tel/fax (059) 8-414-414; 8-414-413
E-mail: office@autohak.com.pl
www.autohak.com.pl

Towing hitch (without electrical set)

Class: **A50-X** Cat. no. **D30A**

Designed for:

Manufacturer: **MERCEDES**

Model: **VITO WSA 639 and VIANO**

produced since 09.2003

Technical data:

D-value: 11,7 kN

maximum trailer weight: **2000 kg**

maximum vertical cup load: **100 kg**

Approval number according to Directive 94/20/EC: e20*94/20*0941*00

Foreword

This towbar is designed according to rules of safety traffic regulations. The towing hitch is a safety component and can be install only by qualified personnel. Any alteration or conversion of the towing hitch is prohibited and would lead to cancellation of design certification. Remove insulating compound and underseal from vehicle (if present) in the area of the matting surfaces of the towing hitch.

The vehicle manufacturer's specifications regarding trailer load and max. vertical cup load are decisive for driving, and values for the towing hitch cannot be exceeded.

D-value formula:

$$\frac{\text{Max trailer weight [kg]} \times \text{Max vehicle weight [kg]}}{\text{Max trailer weight [kg]} + \text{Max vehicle weight [kg]}} \times \frac{9,81}{1000} = D \text{ [kN]}$$

FITTING INSTRUCTION

Clamp mark in acc. with		Cables joining
ISO	PN	
1	L	Left directional lights
2	+	Rear fog lights
3	31	Ground
4	R	Right directional lights
5	58R	Right side parking lights
6	54	Stoplights
7	58L	Left side parking lights

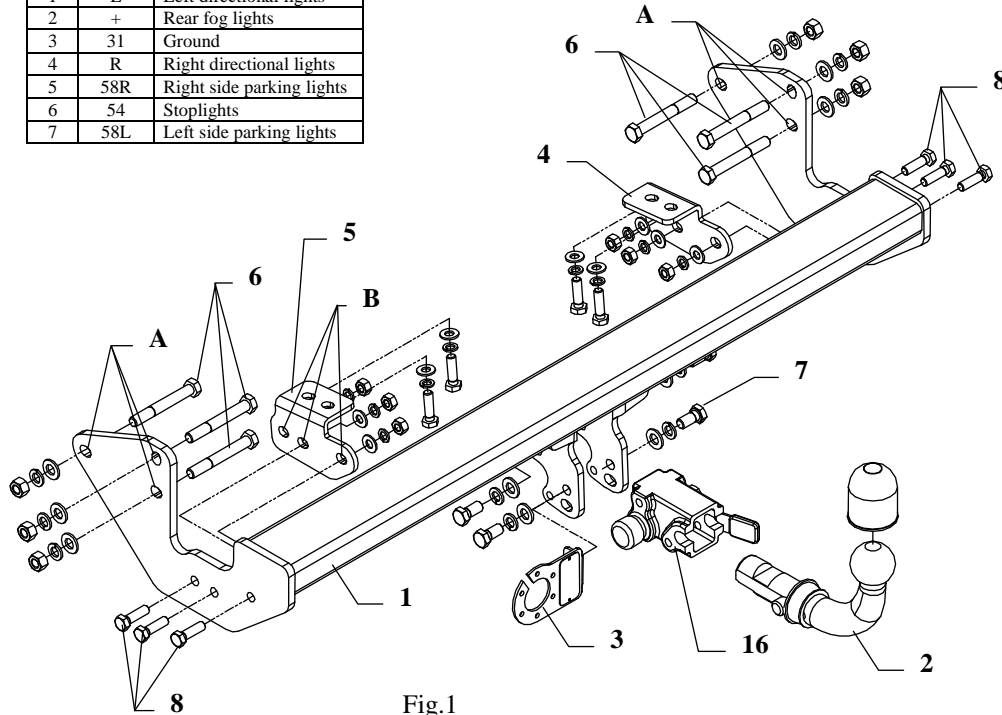

Fig.1

This towbar is designed to assembly in following cars:
MERCEDES VITO WSA 639 and MERCEDES VIANO, produced since 09.2003, catalogue no. **D30** and is prepared to tow trailers max total weight **2000 kg** and max vertical load **100 kg**.

From manufacturer

Thank you for buying our product. Their reliability has been confirmed in many tests. Reliability of towbar depends also on correct assembly and right operation. For this reasons we kindly ask to read carefully this instruction and apply to hints.

The towbar should be install in points described by a car producer.

The instruction of the assembly

1. Disassemble bumper and original tow handle (not used any more).
2. Put main bar of the towbar (pos. 1) in that way, so holes (pos. A) agree with holes in car frame and fix it using bolts M12x90mm (pos. 6).
3. Brackets (pos. 4 and 5) fix to cross bar and through holes (pos. B) fix with main bar (pos. 1) using bolts M10x35mm (pos. 8).

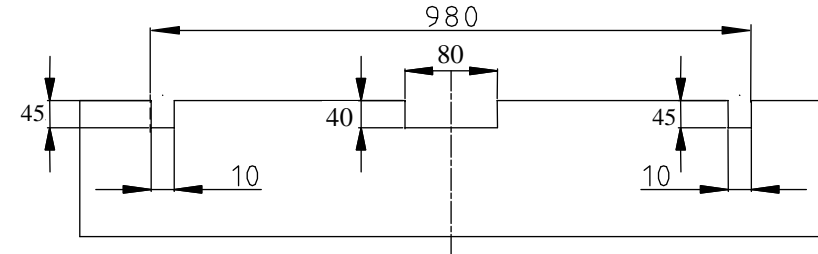

Fig.2

4. Fix bumper after cut his fragment – see fig. 2 (inside, central part).
5. Fix body of the automat (pos. 16) and the socket plate (pos. 3) using bolts M12x25mm (pos. 7) from accessories. Place tow-ball (pos. 2) according to supplied instruction.
6. Tighten all bolts according to the torque shown in the table.
7. Connect electric wires of 7-poles socket according to the instruction of the car. (Recommend to make at authorized service station).
8. Complete the paint coating damaged during instalment.

Torque settings for nuts and bolts (8,8):

M6 - 11 Nm	M8 - 25 Nm	M10 - 50 Nm
M12 - 87 Nm	M14 - 138 Nm	M16 - 210 Nm

NOTE

After install the towbar you should get adequate note in registration book (at authorised service station).The car should be equipped with:

- Indicators
- Tow mirrors

After 1000km of exploitation check all bolts. The ball of towbar must be always kept clear and conserve with a grease.