

## FITTING INSTRUCTION

Clamp mark in acc. with		Cables joining
ISO	PN	
1	L	Left directional lights
2	+	Rear fog lights
3	31	Ground
4	R	Right directional lights
5	58R	Right side parking lights
6	54	Stoplights
7	58L	Left side parking lights

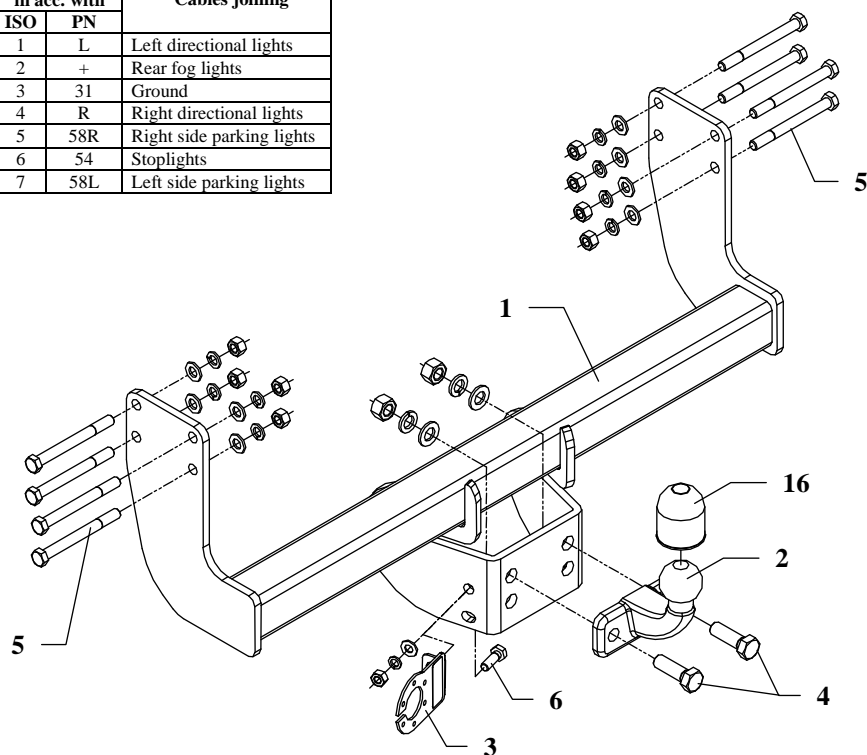

This towing hitch is designed to assembly in following cars: **MERCEDES SPRINTER, VOLKSWAGEN CRAFTER 5 ton, loading platform, double wheels** produced since 2006, catalogue no. **D40** and is prepared to tow trailers max total weight up to **3500 kg** and max vertical mass **140 kg**.

### *From manufacturer*

Thank you for buying our product. Their reliability has been confirmed in many tests. Reliability of towing hitch depends also on correct assembly and right operation. For this reasons we kindly ask to read carefully this instruction and apply to hints.

*The towing hitch should be installed in points described by a car producer.*

## The instruction of the assembly

1. Disassemble a rear panel.
2. Between handles of panel slip main bar of the towbar this way, so holes of main bar agree with holes in brackets of the panel. If necessary relax bolts fastening panel with its brackets. NOTE! Cut out fragments of panel (at ball's bracket) if necessary.
3. Fix panel and main bar with car's frame using bolts M12x120mm (pos. 5) from equipment.
4. Fix tow-ball (pos. 2) using bolts M16x50mm (pos. 4) from equipment.
5. Fix socket plate (pos. 3) using bolt M10x30mm (pos. 6) as shown on the figure.
6. Tighten all bolts according to the torque shown in the table.
7. Connect electric wires of 7-poles socket according to the instruction of the car. (Recommend to make at authorized service station).
8. Complete paint layer damaged during installation.

Torque settings for nuts and bolts (8,8):

<b>M6</b> - 11 Nm	<b>M8</b> - 25 Nm	<b>M10</b> - 50 Nm
<b>M12</b> - 87 Nm	<b>M14</b> - 138 Nm	<b>M16</b> - 210 Nm











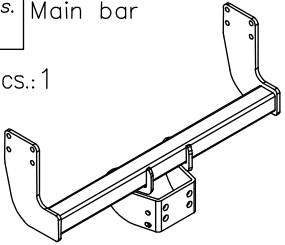

### NOTE

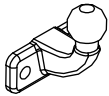
After installation of the towing hitch you should get adequate note in registration book (at authorised service station).The car should be equipped with:

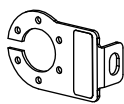
- Indicators
- Tow mirrors

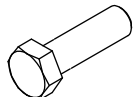
Check all bolts and nuts after **1000 km** of exploitation. The ball of the towing hitch must be always kept clear and conserve with a grease.

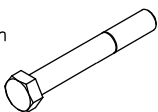
Part list:

Pos. 1 Main bar PCS.: 1 	Pos. 6 Bolt 8,8 B M10x30mm PCS.: 1 	Pos. 12 Spring washer Ø10mm PCS.: 1 
	Pos. 7 Plain washer Ø17mm PCS.: 2 	Pos. 13 Nut 8 B M16 PCS.: 2 
Pos. 2 Tow ball PCS.: 1 	Pos. 8 Plain washer Ø12mm PCS.: 8 	Pos. 14 Nut 8 B M12 PCS.: 8 
Pos. 3 Socket plate PCS.: 1 	Pos. 9 Plain washer Ø10mm PCS.: 1 	Pos. 15 Nut 8 B M10 PCS.: 1 
Pos. 4 Bolt 8,8 B M16x50mm PCS.: 2 	Pos. 10 Spring washer Ø16mm PCS.: 2 	Pos. 16 Ball cover PCS.: 1 
Pos. 5 Bolt 8,8 B M12x120mm PCS.: 8 	Pos. 11 Spring washer Ø12mm PCS.: 8 	



**PPUH AUTO-HAK S.J.**

Produkcja Zaczepów Kulowych  
Henryk & Zbigniew Nejman  
76-200 SŁUPSK ul. Słoneczna 16K  
tel/fax (059) 8-414-414; 8-414-413  
E-mail: [office@autohak.com.pl](mailto:office@autohak.com.pl)  
[www.autohak.com.pl](http://www.autohak.com.pl)

**Towing hitch (without electrical set)**

Class: **A50-X** Cat. no. **D40**

Designed for:

**MERCEDES SPRINTER**  
**VOLKSWAGEN CRAFTER**

Type: **5 ton, loading platform, double wheels**  
produced since 2006

Technical data:

**D-value: 20,2 kN**

maximum trailer weight: **3500 kg**

maximum vertical cup mass: **140 kg**

**Approval number according to Directive 94/20/EC: e20\*94/20\*0512\*00**

**Foreword**

This towing hitch is designed according to rules of safety traffic regulations. The towing hitch is a safety component and can be install only by qualified personnel. Any alteration or conversion of the towing hitch is prohibited and would lead to cancellation of design certification. Remove insulating compound and underseal from vehicle (if present) in the areas of the matting surfaces of the towing hitch. The vehicle manufacturer's specifications regarding trailer load and max. vertical cup mass are decisive for driving whereat values for the towing hitch cannot be exceeded.

*D-value formula:*

$$\frac{\text{Max trailer weight [kg]} \times \text{Max vehicle weight [kg]}}{\text{Max trailer weight [kg]} + \text{Max vehicle weight [kg]}} \times \frac{9,81}{1000} = D \text{ [kN]}$$