

FITTING INSTRUCTION

Clamp mark in acc. with		Cables joining
ISO	PN	
1	L	Left directional lights
2	+	Rear fog lights
3	31	Ground
4	R	Right directional lights
5	58R	Right side parking lights
6	54	Stoptlights
7	58L	Left side parking lights

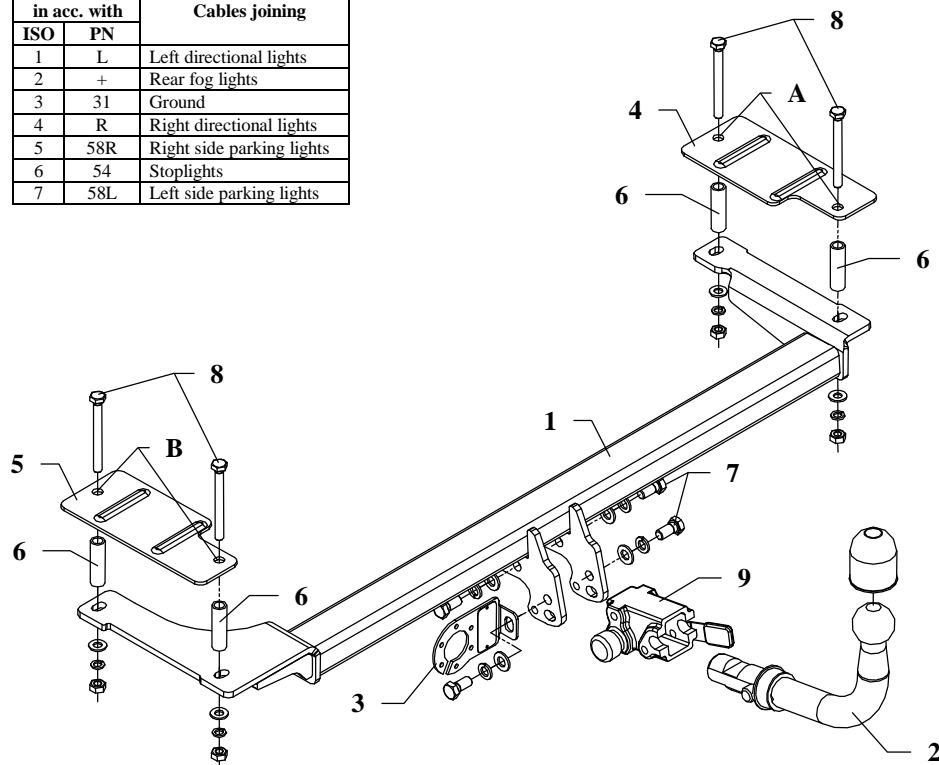

This towbar is designed to assembly in following cars:
OPEL VECTRA "A", 5 doors, produced since 1988 till 09.1995, catalogue no. **E011A** and is prepared to tow trailers max total weight **1700 kg** and max vertical load **75 kg**.

From manufacturer

Thank you for buying our product. Their reliability has been confirmed in many tests. Reliability of towbar depends also on correct assembly and right operation. For this reasons we kindly ask to read carefully this instruction and apply to hints.

The towbar should be install in points described by a car producer.

The instruction of the assembly

1. Remove the fit carpet from the trunk.
2. In original marked points on the left and right side inside the trunk drill holes using bit $\varnothing 17,5\text{mm}$. Two per each side.
3. To made holes put distance sleeves (pos. 6) from accessories and put on fish-plates (pos. 4 and 5).
4. Put the main bar of the towbar (pos. 1) underneath the car and through holes (pos. A and B), distance sleeves (pos. 6) and fish-plates in the trunk (pos. 4 and 5) fix together using bolts M10x100mm (pos. 8), as shown on the drawing.
5. Fix body of the automat (pos. 9) and the socket plate (pos. 3) using bolts M12x25mm (pos. 7) from accessories. Place tow-ball (pos. 2) according to supplied instruction.
6. Tighten all bolts according to the torque shown in the table.
7. Connect electric wires of 7-poles socket according to the instruction of the car. (Recommend to make at authorized service station).
8. Complete paint layer damaged during installation.

Torque settings for nuts and bolts (8,8):	
M 8 - 25 Nm	M 10 - 55 Nm
M 12 - 85 Nm	M 14 - 135 Nm



NOTE

After install the towbar you should get adequate note in registration book (at authorised service station).The car should be equipped with:

- Indicators
- Tow mirrors

After 1000km check all bolts. The ball of towbar must be always kept clear and conserve with a grease.

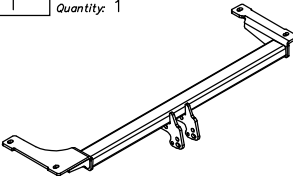
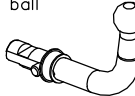
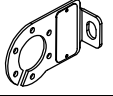
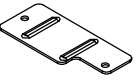
Towbar accessories:

Pos. 1 Name: Main bar Quantity: 1	Pos. 5 Name: Left fish-plate Quantity: 1	Pos. 11 Name: Plain washer Quantity: 4 Dim.: ϕ 13 mm
	Pos. 6 Name: Distance sleeve Quantity: 4 Dim.: ϕ 17.2x2.35mm L=59mm	Pos. 12 Name: Plain washer Quantity: 4 Dim.: ϕ 10,5 mm
Pos. 2 Name: Tow ball Quantity: 1	Pos. 7 Name: Bolt 8,8 B Quantity: 4 Dim.: M12x25mm	Pos. 13 Name: Spring washer Quantity: 4 Dim.: ϕ 12,2 mm
	Pos. 8 Name: Bolt 8,8 B Quantity: 4 Dim.: M10x100mm	Pos. 14 Name: Spring washer Quantity: 4 Dim.: ϕ 10,2 mm
Pos. 3 Name: Socket plate Quantity: 1		Pos. 9 Name: Body of the automat Quantity: 1
Pos. 4 Name: Right fish-plate Quantity: 1		Pos. 15 Name: Ball cover Quantity: 1
	Pos. 10 Name: Nut 8 B Quantity: 4 Dim.: M10	Pos. 16 Name: Body plug Quantity: 1
		



PPUH AUTO-HAK S.J.

Produkcja Haków Holowniczych
Henryk & Zbigniew Nejman
76-200 SŁUPSK ul. Słoneczna 16K
tel/fax (059) 8-414-414; 8-414-413
E-mail: office@autohak.com.pl
www.autohak.com.pl

Towing hitch (without electrical set)

Class: **A50-X** Cat. no. **E011A**

Designed for:

Manufacturer: **OPEL**

Model: **VECTRA "A"**

Type: **5 doors**

produced since 1988 till 09.1995

Technical data:

D-value: 8,58 kN

maximum trailer weight: **1700 kg**

maximum vertical cup load: **75 kg**

Approval number according to Directive 94/20/EC: **e20*94/20*0225*00**

Foreword

This towbar is designed according to rules of safety traffic regulations. The towing hitch is a safety component and can be install only by qualified personnel. Any alteration or conversion of the towing hitch is prohibited and would lead to cancellation of design certification. Remove insulating compound and underseal from vehicle (if present) in the area of the matting surfaces of the towing hitch. The vehicle manufacturer's specifications regarding trailer load and max. vertical cup load are decisive for driving whereat values for the towing hitch cannot be exceeded.

D-value formula:

$$\frac{\text{Max trailer weight [kg]} \times \text{Max vehicle weight [kg]}}{\text{Max trailer weight [kg]} + \text{Max vehicle weight [kg]}} \times \frac{9,81}{1000} = D \text{ [kN]}$$