

## Towing hitch accessories:

Pos. 1	Name: Main bar Quantity: 1	Pos. 5	Name: Distance sleeve Quantity: 6 Dim.: $\varnothing 17.2 \times 2.3 \text{ mm}$ L=59mm
Pos. 2	Name: Tow ball Quantity: 1	Pos. 7	Name: Nut 8 B Quantity: 6 Dim.: M10
Pos. 3	Name: Socket plate Quantity: 1	Pos. 8	Name: Plain washer Quantity: 6 Dim.: $\varnothing 10,5 \text{ mm}$
Pos. 4	Name: Fish-plate Quantity: 2	Pos. 9	Name: Spring washer Quantity: 6 Dim.: $\varnothing 10,2 \text{ mm}$



**PPUH AUTO-HAK Sp.J.**

Produkcja Zaczepów Kulowych  
Henryk & Zbigniew Nejman  
76-200 SŁUPSK ul. Słoneczna 16K  
tel/fax (059) 8-414-414; 8-414-413  
E-mail: [office@autohak.com.pl](mailto:office@autohak.com.pl)  
[www.autohak.com.pl](http://www.autohak.com.pl)

## Towing hitch (without electrical set)

Class: **A50-X** Cat. no. **E11A**

Designed for:

Manufacturer: **OPEL**

Model: **VECTRA (A)**

Type: **4 doors, except 4x4**

produced since 09.1988 till 08.1995

Technical data:

**D-value: 8,58 kN**

maximum trailer weight: **1700 kg**

maximum vertical cup load: **75 kg**

Approval number according to Directive 94/20/EC: **e20\*94/20\*0047\*00**

### Foreword

This towing hitch is designed according to rules of safety traffic regulations. The towing hitch is a safety component and can be install only by qualified personnel. Any alteration or conversion of the towing hitch is prohibited and would lead to cancellation of design certification. Remove insulating compound and underseal from vehicle (if present) in the area of the matting surfaces of the towing hitch. The vehicle manufacturer's specifications regarding trailer mass and max. vertical cup mass are decisive for driving whereat values for the towing hitch cannot be exceeded.

*D-value formula:*

$$\frac{\text{Max trailer weight [kg]} \times \text{Max vehicle weight [kg]}}{\text{Max trailer weight [kg]} + \text{Max vehicle weight [kg]}} \times \frac{9,81}{1000} = D \text{ [kN]}$$

## FITTING INSTRUCTION

Clamp mark in acc. with		Cables joining
ISO	PN	
1	L	Left directional lights
2	+	Rear fog lights
3	31	Ground
4	R	Right directional lights
5	58R	Right side parking lights
6	54	Stoplights
7	58L	Left side parking lights

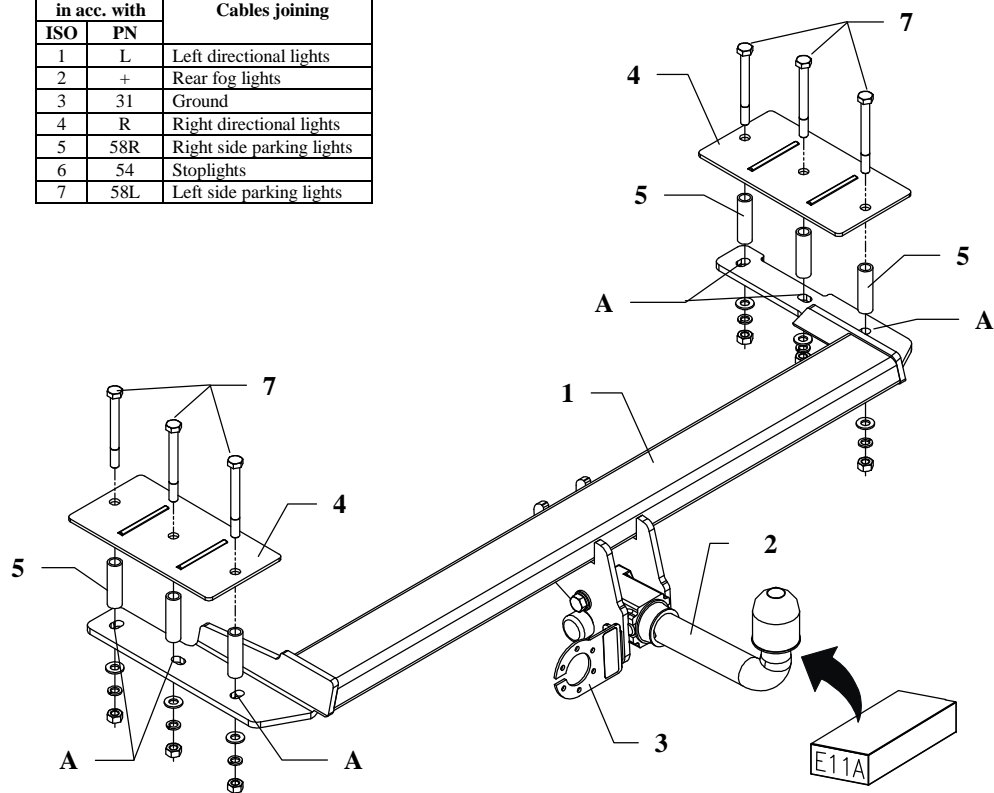

This towing hitch is designed to assembly in following car:  
**OPEL VECTRA (A), 4 doors, except 4x4**, produced since 09.1988 till 08.1995, catalogue no. **E11A** and is prepared to tow trailers max total weight **1700 kg** and max vertical load **75 kg**.

### *From manufacturer*

Thank you for buying our product. Their reliability has been confirmed in many tests. Reliability of towing hitch depends also on correct assembly and right operation. For this reasons we kindly ask to read carefully this instruction and apply to hints.

*The towing hitch should be install in points described by a car producer.*

## The instruction of the assembly

1. Disassemble bumper and fitted carpet from the trunk.
2. In original marked points inside the trunk (on the left and right side) drill per three holes (pos. A) using bit  $\varnothing 17,5\text{mm}$ .
3. To drilled holes put distance sleeves (pos. 5) from accessories and put fish-plates (pos. 4).
4. Underneath the car put the main bar of the towing hitch (pos. 1) and through holes (pos. A), distance sleeves (pos. 5) and fish-plates (pos. 4) fix using bolts M10x100mm (pos. 6).
5. Fix body of the automat and place tow-ball according to supplied instruction. Note! Remember to place socket plate (pos. 3) as shown on the drawing 1.
6. Tighten all bolts according to the torque shown in the table.
7. Connect electric wires of 7-poles socket according to the instruction of the car. (Recommend to make at authorized service station)
8. Complete paint layer damaged during installation.

Torque settings for nuts and bolts (8,8):

<b>M6</b> - 11 Nm	<b>M 8</b> - 25 Nm	<b>M 10</b> - 50 Nm
<b>M 12</b> - 87 Nm	<b>M 14</b> - 138 Nm	<b>M16</b> - 210 Nm

### NOTE

After installation of a towing hitch you should get adequate note in registration book (at authorised service station). The car should be equipped with:

- Indicators
- Tow mirrors

After 1000km of exploitation check all bolts and nuts. The ball of towing hitch must be always kept clear and conserve with a grease.