

FITTING INSTRUCTION

Clamp mark in acc. with		Cables joining
ISO	PN	
1	L	Left directional lights
2	+	Rear fog lights
3	31	Ground
4	R	Right directional lights
5	58R	Right side parking lights
6	54	Stoptlights
7	58L	Left side parking lights

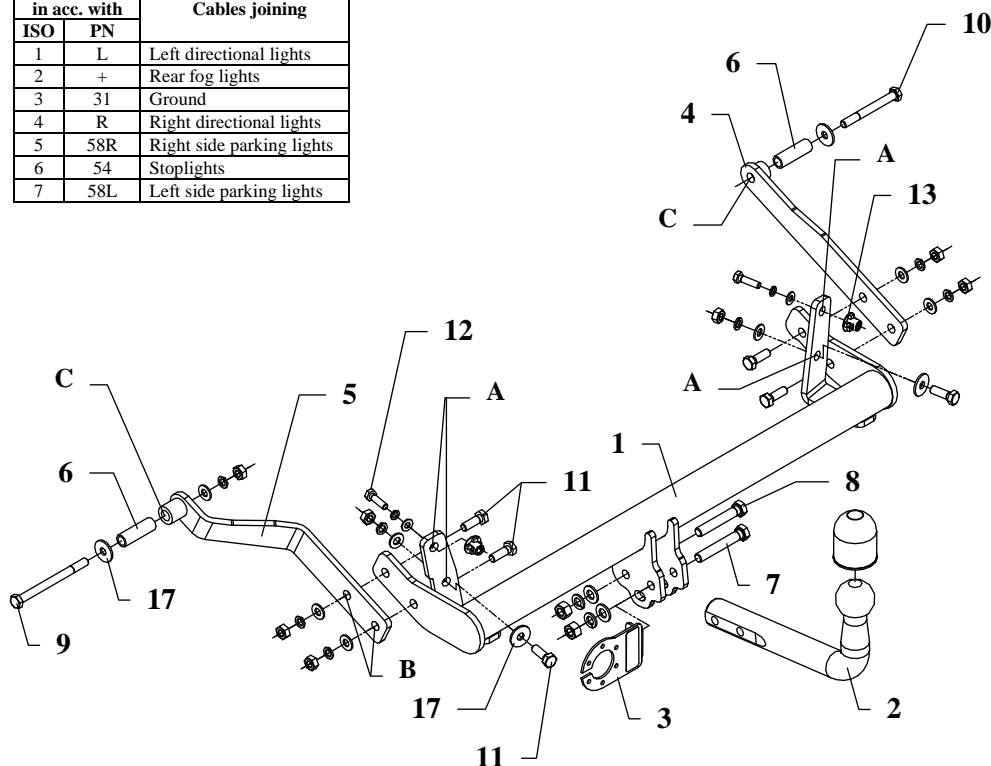

This towing hitch is designed to assembly in following cars:
RENAULT MEGANE I, 5 doors, except Coupe/Cabrio produced since 11.1995 till 02.1999, catalogue no. **G21** and is prepared to tow trailers max total weight **1300 kg** and max vertical load **65 kg**.

From manufacturer

Thank you for buying our product. Their reliability has been confirmed in many tests. Reliability of towing hitch depends also on correct assembly and right operation. For this reasons we kindly ask to read carefully this instruction and apply to hints.

The towing hitch should be install in points described by a car producer.

The instruction of the assembly

- Underside the car (in the rear panel) find plugged holes on the right and left side, then make them available and put round cage nut together with M8 nut (pos. 15).
- Position the main bar of the towing hitch (pos. 1) underside the car and fix it using bolts M8x30mm (pos. 12) and M10x30mm (pos. 11) together with large washers (pos. 17) through the holes (pos. A).
- Outside original car holes put the distance sleeves (pos. 6)
- Position the side brackets (pos. 4 and 5) to the main bar of the towing hitch (pos. 1) and fix it using bolts M10x30mm (pos. 11) through the holes (pos. B).
- Fix through the distance sleeves and towing hitch holes (pos. C) using M10x120mm (pos. 9) and M10x90mm (pos. 10).
- Tighten all nuts and bolts according to the torque shown in the table.
- Fix tow ball (pos. 2) using bolt M12x75mm (pos. 7) and M12x70mm (pos. 8). With bolt M12x75mm fix also a socket plate (pos. 3). See figure 1.
- Connect the electric wires according to the instructions of the car.
- Complete the paint cover of towing hitch (during the mounting paint cover could be destroyed).

Torque settings for nuts and bolts (8,8):

M 8 - 25 Nm	M 10 - 55 Nm
M 12 - 85 Nm	M 14 - 135 Nm

NOTE

After install the towing hitch you should get adequate note in registration book (at authorised service station).The car should be equipped with:

- Indicators
- Tow mirrors

After 1000km check all bolts and nuts. The ball of towing hitch must be always kept clear and conserve with a grease.

Towing hitch accessories:

Pos. 1 Main bar PCS.: 1	Pos. 6 Distance sleeve ø17.2xø2.3mm L=53mm PCS.: 2	Pos. 12 Bolt 8,8 B M8x30mm PCS.: 2	Pos. 18 Plain washer ø10.5mm PCS.: 7
Pos. 2 Tow ball PCS.: 1	Pos. 7 Bolt 8,8 B M12x75mm PCS.: 1	Pos. 13 Caget nut M8 PCS.: 2	Pos. 19 Plain washer ø8.5mm PCS.: 2
Pos. 3 Socket plate PCS.: 1	Pos. 8 Bolt 8,8 B M12x70mm PCS.: 1	Pos. 14 Nut 8 B M12 PCS.: 2	Pos. 20 Spring washer ø12.2mm PCS.: 2
Pos. 4 Right bracket PCS.: 1	Pos. 9 Bolt 8,8 B M10x120mm PCS.: 1	Pos. 15 Nut 8 B M10 PCS.: 7	Pos. 21 Spring washer ø10.2mm PCS.: 7
Pos. 5 Left bracket PCS.: 1	Pos. 10 Bolt 8,8 B M10x90mm PCS.: 1	Pos. 16 Plain washer ø13mm PCS.: 2	Pos. 22 Spring washer ø8.2mm PCS.: 2
	Pos. 11 Bolt 8,8 B M10x30mm PCS.: 6	Pos. 17 Plain washer ø30xø10.5x2.5mm PCS.: 4	Pos. 23 Ball cover PCS.: 1



PPUH AUTO-HAK S. J.

Produkcja Zaczepów Kulowych
Henryk & Zbigniew Nejman
76-200 SŁUPSK ul. Słoneczna 16K
tel/fax (059) 8-414-414; 8-414-413
E-mail: office@autohak.com.pl
www.autohak.com.pl

Towing hitch (without electrical set)

Class: **A50-X** Cat. no. **G21**

Designed for:

Manufacturer: **RENAULT**

Model: **MEGANE I**

Type: **5 doors, except Coupe/Cabrio**

produced since 11.1995 till 02.1999

Technical data:

D-value: 7,15 kN

maximum trailer weight: **1300 kg**

maximum vertical cup load: **65 kg**

Approval number acc. to regulations EKG/ONZ 55.01: E20-55R-01 0901

Foreword

This towing hitch is designed according to rules of safety traffic regulations. The towing hitch is a safety component and can be install only by qualified personnel. Any alteration or conversion of the towing hitch is prohibited and would lead to cancellation of design certification. Remove insulating compound and underseal from vehicle (if present) in the area of the matting surfaces of the towing hitch. The vehicle manufacturer's specifications regarding trailer load and max. vertical cup load are decisive for driving, and values for the towing hitch cannot be exceeded.

D-value formula:

$$\frac{\text{Max trailer weight [kg]} \times \text{Max vehicle weight [kg]}}{\text{Max trailer weight [kg]} + \text{Max vehicle weight [kg]}} \times \frac{9,81}{1000} = D \text{ [kN]}$$