

PPUH AUTO-HAK Sp.J.

Henryk & Zbigniew Nejman
ul. Słoneczna 16K 76-200 SŁUPSK
POLAND

tel/fax +48 059 8-414-414; 8-414-413

e-mail: office@autohak.com.pl

www.autohak.com.pl



AUTO-HAK



DACIA SANDERO 5D

(also with factory-fitted
LPG installation)

Cat. no:

G75



01.2013 →



E20-55R-01 3165



2h



6,47 kN



R=1100 kg



S=75 kg

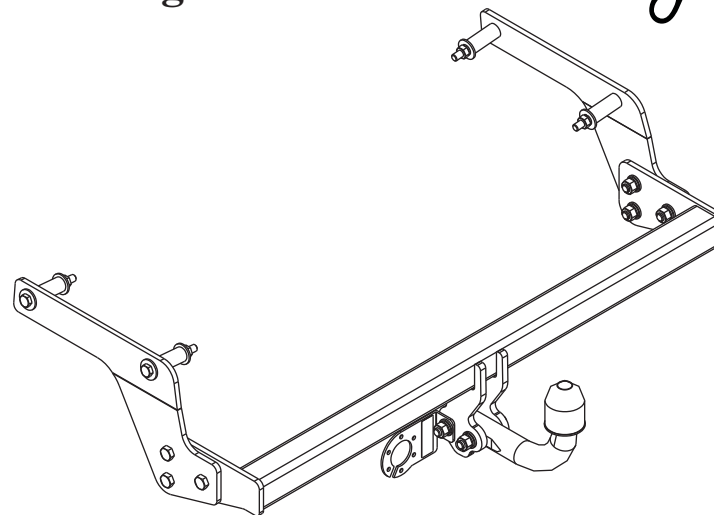

M6 - 11 Nm
M10 - 50 Nm
M14 - 138 Nm

M8 - 25 Nm
M12 - 87 Nm
M16 - 210 Nm



0 km →



1000 km