

FITTING INSTRUCTION

Clamp mark in acc. with		Cables joining
ISO	PN	
1	L	Left directional lights
2	+	Rear fog lights
3	31	Ground
4	R	Right directional lights
5	58R	Right side parking lights
6	54	Stoplights
7	58L	Left side parking lights

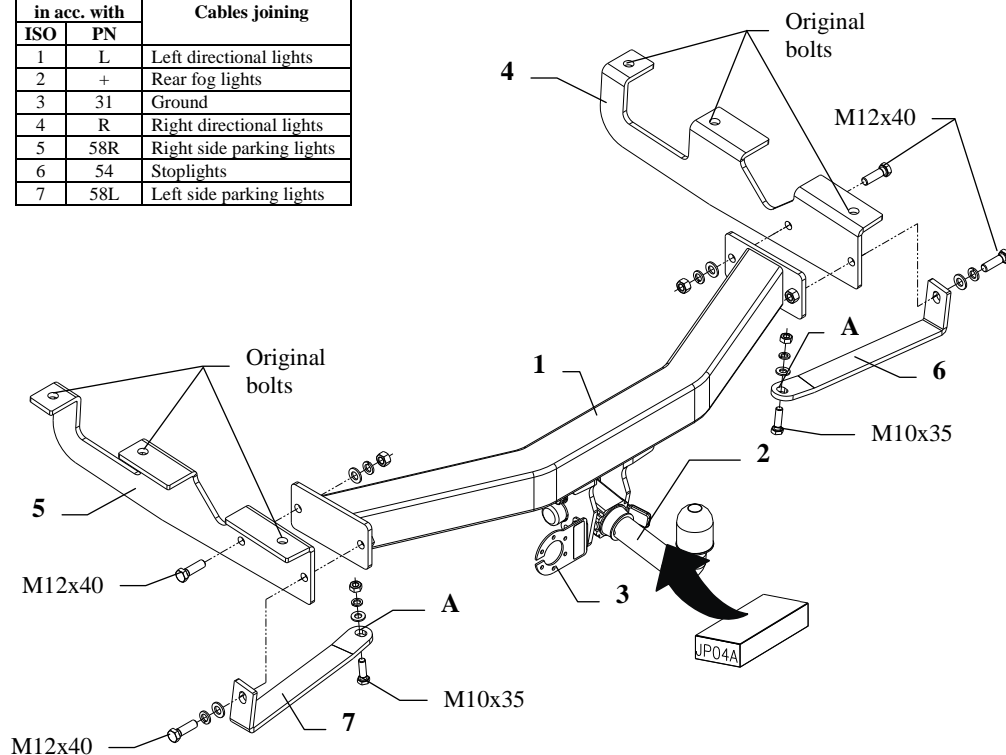

This towbar is designed to assembly in following cars:
JEEP GRAND CHEROKEE (WJ/WG), produced since 04.1999 till 05.2005, catalogue no. **JP04A** and is prepared to tow trailers max total weight up to **3500 kg** and max vertical load **140 kg**.

From manufacturer

Thank you for buying our product. Their reliability has been confirmed in many tests. Reliability of towbar depends also on correct assembly and right operation. For this reasons we kindly ask to read carefully this instruction and apply to hints.

The towbar should be install in points described by a car producer.

The instruction of the assembly

1. Disassemble the towing eye and unscrew the bolts from the chassis members (on the left and right side).
 2. Disassemble brackets (2 pieces of flatten pipes), if these parts are located in the car - these parts are not used any more.
 3. From below cut the bumper in its axis (fragment 80x150mm).
 4. Position side brackets of the towbar (pos. 4 and 5) to the left and right chassis member (see the fig.) and fix it using original bolts.
 5. Slide the main bar of the towbar (pos. 1) between brackets (pos. 4 and 5) and fix it together with the brackets (pos. 6 and 7) using M12x40mm (pos. 8) bolts (see the figure) - through the holes (pos. A) of brackets (pos. 6 and 7) fix to the spare wheel box using M10x35mm (pos. 9) bolts.
- Attention!** In case lack of fabric holes it should be drilled ($\varnothing 1$ mm).
6. Fix body of the automat and place tow-ball according to supplied instruction. Note! Remember to place socket plate (pos. 3) as shown on the drawing 1. Tighten all nuts and bolts according to the torque shown in the table.
 7. Connect to the electric wires according to the instructions of the car.
 8. Complete the paint cover of towbar (during the mounting paint cover could be destroyed).

Torque settings for nuts and bolts (8,8):

M6 - 11 Nm	M8 - 25 Nm	M10 - 50 Nm
M12 - 87 Nm	M14 - 138 Nm	M16 - 210 Nm









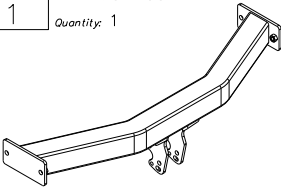
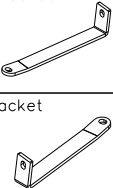

NOTE

After install the towbar you should get adequate note in registration book (at authorised service station). The car should be equipped with:

- Indicators
- Tow mirrors

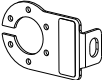
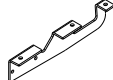
After 1000km of exploitation check all bolts and nuts. The ball of towbar must be always kept clear and conserve with a grease.

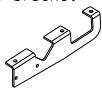
Towbar accessories:

Pos. 1 Name: Main bar Quantity: 1	Pos. 6 Name: Right bracket Quantity: 1	Pos. 12 Name: Plain washer Quantity: 4 Dim.: Ø 13 mm
	Pos. 7 Name: Left bracket Quantity: 1	Pos. 13 Name: Plain washer Quantity: 2 Dim.: Ø 10,5 mm
	Pos. 8 Name: Bolt 8,8 B Quantity: 4 Dim.: M12x40mm	Pos. 14 Name: Spring washer Quantity: 4 Dim.: Ø 12,2 mm
Pos. 2 Name: Tow ball Quantity: 1		
	Pos. 9 Name: Bolt 8,8 B Quantity: 2 Dim.: M10x35mm	Pos. 15 Name: Spring washer Quantity: 2 Dim.: Ø 10,2 mm
Pos. 3 Name: Socket plate Quantity: 1		
	Pos. 4 Name: Right side bracket Quantity: 1	Pos. 10 Name: Nut 8 B Quantity: 2 Dim.: M12
		Pos. 5 Name: Left side bracket Quantity: 1
	Pos. 11 Name: Nut 8 B Quantity: 2 Dim.: M10	



PPUH AUTO-HAK Sp.J.

Produkcja Zaczepów Kulowych
Henryk & Zbigniew Nejman
76-200 SŁUPSK ul. Słoneczna 16K
tel/fax (059) 8-414-414; 8-414-413
E-mail: office@autohak.com.pl
www.autohak.com.pl

Towing hitch (without electrical set)

Class: **A50-X** Cat. no. **JP04A**

Designed for:

Manufacturer: **JEEP**

Model: **GRAND CHEROKEE (WJ/WG)**

produced since 04.1999 till 05.2005

Technical data:

D-value: 14,3 kN

maximum trailer weight: **3500 kg**

maximum vertical cup load: **140 kg**

Approval number according to Directive 94/20/EC: e20*94/20*1018*00

Foreword

This towbar is designed according to rules of safety traffic regulations. The towing hitch is a safety component and can be install only by qualified personnel. Any alteration or conversion of the towing hitch is prohibited and would lead to cancellation of design certification. Remove insulating compound and underseal from vehicle (if present) in the area of the matting surfaces of the towing hitch. The vehicle manufacturer's specifications regarding trailer load and max. vertical cup load are decisive for driving whereat values for the towing hitch cannot be exceeded.

D-value formula:

$$\frac{\text{Max trailer weight [kg]} \times \text{Max vehicle weight [kg]}}{\text{Max trailer weight [kg]} + \text{Max vehicle weight [kg]}} \times \frac{9,81}{1000} = D \text{ [kN]}$$