

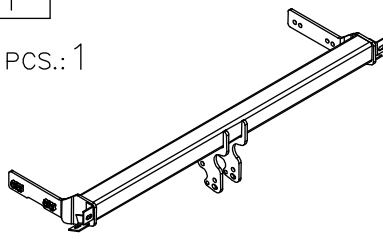

Towbar accessories:

Pos. 1	Main bar 	Pos. 4	Fish-plate 160x48x4mm 
PCS.: 1		PCS.: 2	
Pos. 2	Tow ball 	Pos. 5	Bolt 8,8 B M10x40mm 
PCS.: 1		PCS.: 4	
Pos. 3	Socket plate 	Pos. 6	Plain washer ø10,5mm 
PCS.: 1		PCS.: 4	
		Pos. 7	Spring washer ø10,2mm 
		PCS.: 4	

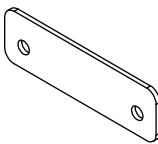
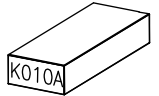
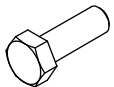
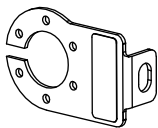

PPUH AUTO-HAK Sp.J.

Produkcja Zaczepów Kulowych
Henryk & Zbigniew Nejman
76-200 SŁUPSK ul. Słoneczna 16K
tel/fax (059) 8-414-414; 8-414-413
E-mail: office@autohak.com.pl
[www. autohak.com.pl](http://www.autohak.com.pl)

Towing hitch (without electrical set)

Class: **A50-X** Cat. no. **K010A**

Designed for:

Manufacturer: **VOLKSWAGEN**

Model: **PASSAT CL**

Type: **version 2**

produced since 04.1988 till 09.1993

Technical data:

D-value: 9,10 kN

maximum trailer weight: **2000 kg**

maximum vertical cup load: **75 kg**

Approval number according to Directive 94/20/EC: e20*94/20*1158*00

Foreword

This towbar is designed according to rules of safety traffic regulations. The towing hitch is a safety component and can be install only by qualified personnel. Any alteration or conversion of the towing hitch is prohibited and would lead to cancellation of design certification. Remove insulating compound and underseal from vehicle (if present) in the area of the matting surfaces of the towing hitch.

The vehicle manufacturer's specifications regarding trailer load and max. vertical cup load are decisive for driving whereat values for the towing hitch cannot be exceeded.

D-value formula:

$$\frac{\text{Max trailer weight [kg]} \times \text{Max vehicle weight [kg]}}{\text{Max trailer weight [kg]} + \text{Max vehicle weight [kg]}} \times \frac{9,81}{1000} = D \text{ [kN]}$$

FITTING INSTRUCTION

Clamp mark in acc. with		Cables joining
ISO	PN	
1	L	Left directional lights
2	+	Rear fog lights
3	31	Ground
4	R	Right directional lights
5	58R	Right side parking lights
6	54	Stoptlights
7	58L	Left side parking lights

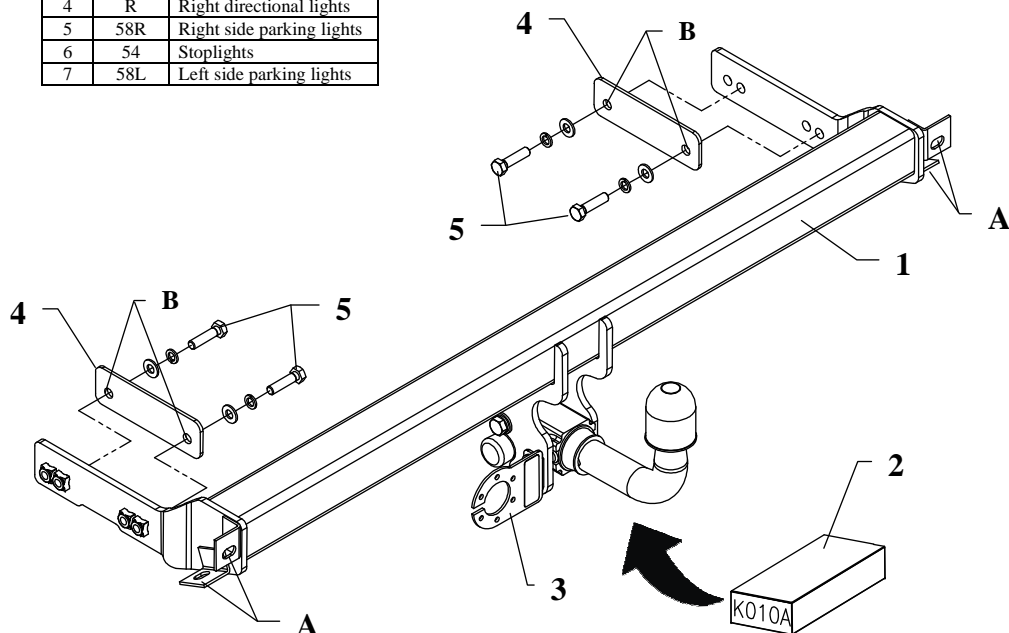

This towbar is designed to assembly in following cars:
VOLKSWAGEN PASSAT CL version 2, produced since 04.1988 till 09.1993, catalogue no. **K010A** and is prepared to tow trailers max total weight **2000 kg** and max vertical load **75 kg**.

From manufacturer

Thank you for buying our product. Their reliability has been confirmed in many tests. Reliability of towbar depends also on correct assembly and right operation. For this reasons we kindly ask to read carefully this instruction and apply to hints.

The towbar should be install in points described by a car producer.

The instruction of the assembly

1. Disassemble the rear bumper and unscrew the fabric supports on the left and right side.
2. In the central inside part of the bumper cut the hole (place is signed).
3. Fix the bumper to the main bar of the towbar (pos. 1) through the holes (pos. A) (there were mounted the supports earlier). Tow-ball put through made hole.
4. Position the bumper to the car and fix it through fish-plates – pos. 4 (position them inside the boot) and the holes (pos. B) using bolts M10x40mm (pos. 5) from the towbar accessories.
5. Fix body of the automat and the socket plate (pos. 3) using bolts M12 from accessories. Place tow-ball (pos. 2) according to supplied instruction.
6. Tighten all nuts and bolts according to the torque shown in the table.
7. Connect electric wires of 7-bolts socket according to the instruction of the car. (Recommend to make at authorized service station).
8. Complete the paint cover of towbar (during the mounting paint cover could be destroyed).

Torque settings for nuts and bolts (8,8):

M6 - 11 Nm	M8 - 25 Nm	M10 - 50 Nm
M12 - 87 Nm	M14 - 138 Nm	M16 - 210 Nm

NOTE

After install the towbar you should get adequate note in registration book (at authorised service station).The car should be equipped with:

- Indicators
- Tow mirrors

After 1000km of exploitation check all bolts and nuts. The ball of towbar must be always kept clear and conserve with a grease.