

FITTING INSTRUCTION

Fig. 1

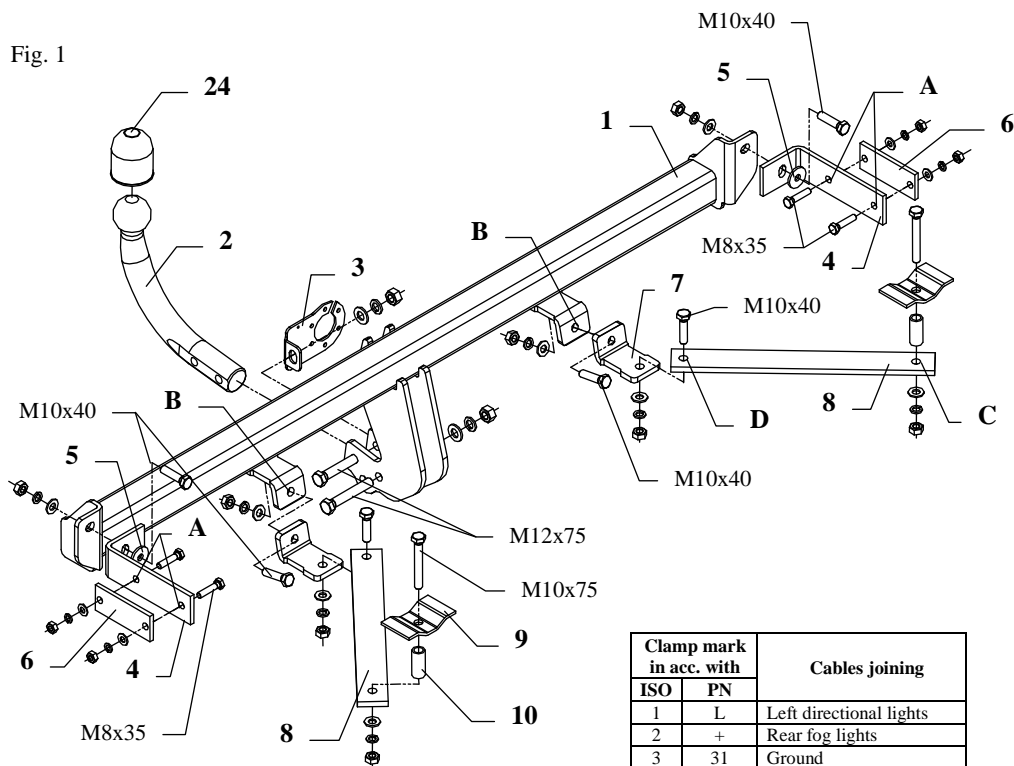

Clamp mark in acc. with		Cables joining
ISO	PN	
1	L	Left directional lights
2	+	Rear fog lights
3	31	Ground
4	R	Right directional lights
5	58R	Right side parking lights
6	54	Stoptlights
7	58L	Left side parking lights

This towbar is designed to assembly in following cars:
VOLKSWAGEN POLO, 3 doors, ESTATE-FOX, produced since 09.1990 till 08.1994, catalogue no. **K02** and is prepared to tow trailers max total weight **1000 kg** and max vertical load **50 kg**.

From manufacturer

Thank you for buying our product. Their reliability has been confirmed in many tests. Reliability of towbar depends also on correct assembly and right operation. For this reasons we kindly ask to read carefully this instruction and apply to hints.

The towbar should be install in points described by a car producer.

The instruction of the assembly

1. Disassemble the bumper.
2. On the back piece are clearly embossed points which one ought to drill with the bit $\varnothing 11\text{mm}$.
3. Apply the main bar of the towbar (pos. 1) on bored holes and fix using bolts M10x40mm (pos. 13) through brackets (pos. 4), which one ought to place inside the trunk (on the right and left side). Use washers $\varnothing 30 \times \varnothing 10,5 \times 2,5\text{mm}$ (pos. 5).
4. Through holes (pos. A) of brackets (pos. 4) drill holes $\varnothing 9\text{mm}$ and then fix using bolts M8x35mm (pos. 14) through plate (pos. 6).
5. Through holes (pos. B) of the towbar drill (in the back piece) holes $\varnothing 11\text{mm}$ and fix with bolts M10x40mm (pos. 13) through angle brackets (pos. 7), which one ought to place from the internal side of the back piece, as showed on the fig. 1.
6. In the chassis member are holes $\varnothing 11\text{mm}$ (from the bottom of the car by piece from the right and left side), which one ought to drill throughly with the bit $\varnothing 11\text{mm}$. Then, in part trunk, drill on the diameter $\varnothing 17\text{mm}$. Into so prepared holes put distance sleeves L=39mm (pos. 10), apply fish-plates (pos. 9) and put bolts M10x75mm (pos. 12), as showed on the fig. 1.
7. So prepared elements of the towbar fix with jibs (pos. 8) in marked points (pos. C and D).
8. Install the bumper after cut out of its fragment 50x150mm, as showed on the fig. 2.

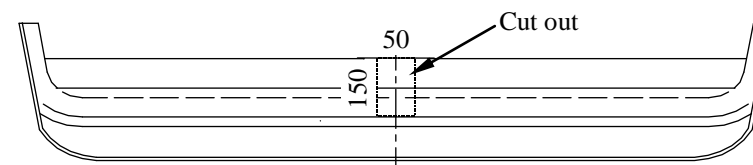

Fig. 2

9. Fix tow-ball (pos. 2) and socket plate (pos. 3) by bolts M12x75mm (pos. 11) from accessories.
10. Tighten all bolts according to the torque shown in the table.
11. Connect electric wires of 7-poles socket according to the instruction of the car. (Recommend to make at authorized service station).
12. Complete paint layer damaged during installation.

Torque settings for nuts and bolts (8,8):	
M 8 - 25 Nm	M 10 - 55 Nm
M 12 - 85 Nm	M 14 - 135 Nm

NOTE











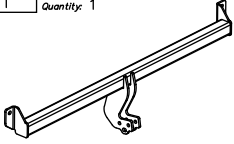



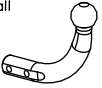



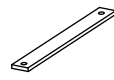

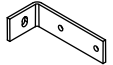

After install the towbar you should get adequate note in registration book (at authorised service station).The car should be equipped with:

- Indicators
- Tow mirrors

After 1000km of exploitation check all bolts and nuts. The ball of towbar must be always kept clear and conserve with a grease.

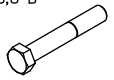

Towbar accessories:

Pos. 1 Name: Main bar Quantity: 1 	Pos. 6 Name: Plate Quantity: 2 	Pos. 12 Name: Bolt 8,8 B Quantity: 2 Dim.: M10x75mm 	Pos. 18 Name: Plain washer Quantity: 2 Dim.: Ø 13 mm 
Pos. 2 Name: Tow ball Quantity: 1 	Pos. 7 Name: Angle bracket Quantity: 2 	Pos. 13 Name: Bolt 8,8 B Quantity: 6 Dim.: M10x40mm 	Pos. 19 Name: Plain washer Quantity: 8 Dim.: Ø 10,5 mm 
Pos. 3 Name: Socket plate Quantity: 1 	Pos. 8 Name: Jib Quantity: 2 	Pos. 14 Name: Bolt 8,8 B Quantity: 4 Dim.: M8x35mm 	Pos. 20 Name: Plain washer Quantity: 4 Dim.: Ø 8,5 mm 
Pos. 4 Name: Bracket Quantity: 2 	Pos. 9 Name: Washer Quantity: 2 	Pos. 15 Name: Nut 8 B Quantity: 2 Dim.: M12 	Pos. 21 Name: Spring washer Quantity: 2 Dim.: Ø 12,2 mm 
Pos. 5 Name: Washer Quantity: 2 Dim.: Ø30xØ10,5x2,5mm 	Pos. 10 Name: Distance sleeve Quantity: 2 Dim.: Ø17,2x2,35mm L=39mm 	Pos. 16 Name: Nut 8 B Quantity: 8 Dim.: M10 	Pos. 22 Name: Spring washer Quantity: 8 Dim.: Ø 10,2 mm 
Pos. 11 Name: Bolt 8,8 B Quantity: 2 Dim.: M12x75mm 	Pos. 17 Name: Nut 8 B Quantity: 4 Dim.: M8 	Pos. 23 Name: Spring washer Quantity: 4 Dim.: Ø 8,2 mm 	Pos. 24 Name: Ball cover Quantity: 1 

Towing hitch (without electrical set)

Class: **A50-X** Cat. no. **K02**

Designed for:

Manufacturer: **VOLKSWAGEN**

Model: **POLO**

Type: **3 doors, ESTATE-FOX**

produced since 09.1990 till 08.1994

Technical data:

D-value: 5,54 kN

maximum trailer weight: **1000 kg**

maximum vertical cup load: **50 kg**

Approval number according to Directive 94/20/EC: e20*94/20*1342*00

Foreword

This towbar is designed according to rules of safety traffic regulations. The towing hitch is a safety component and can be install only by qualified personnel. Any alteration or conversion of the towing hitch is prohibited and would lead to cancellation of design certification. Remove insulating compound and underseal from vehicle (if present) in the area of the matting surfaces of the towing hitch. The vehicle manufacturer's specifications regarding trailer load and max. vertical cup load are decisive for driving whereat values for the towing hitch cannot be exceeded.

D-value formula:

$$\frac{\text{Max trailer weight [kg]} \times \text{Max vehicle weight [kg]}}{\text{Max trailer weight [kg]} + \text{Max vehicle weight [kg]}} \times \frac{9,81}{1000} = D \text{ [kN]}$$