

FITTING INSTRUCTION

Clamp mark in acc. with		Cables joining
ISO	PN	
1	L	Left directional lights
2	+	Rear fog lights
3	31	Ground
4	R	Right directional lights
5	58R	Right side parking lights
6	54	Stoplights
7	58L	Left side parking lights

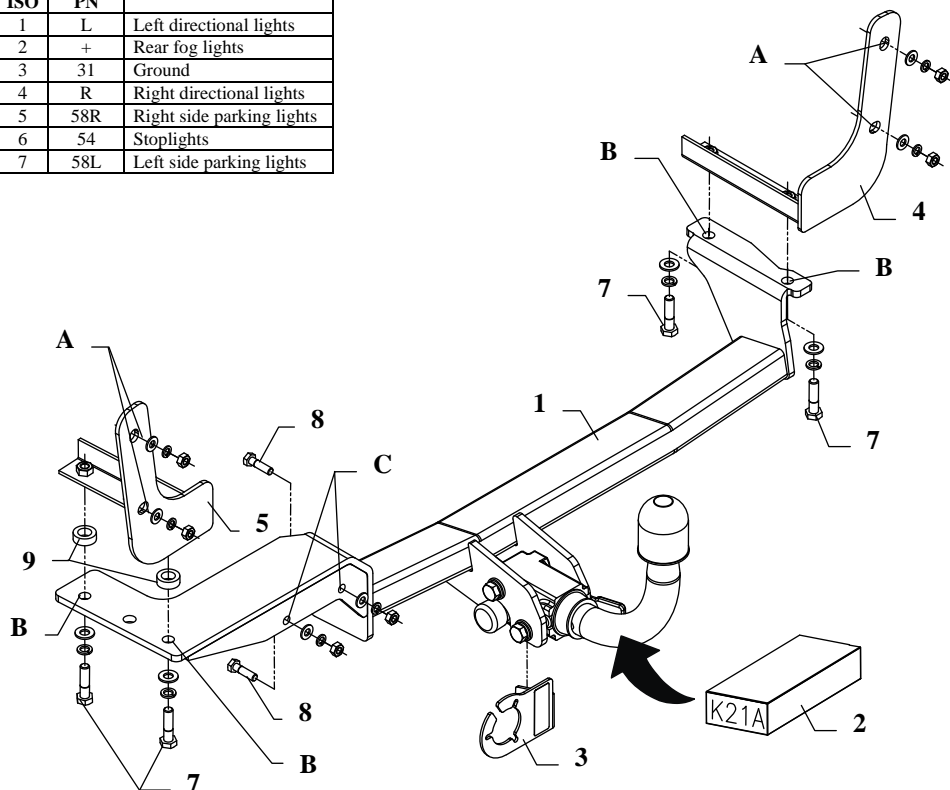

This towbar is designed to assembly in following car:
VOLKSWAGEN POLO 3/5 doors (6N1), produced since 09.1994 till 09.1999, catalogue no. **K21A** and is prepared to tow trailers max total weight **1200 kg** and max vertical load **50 kg**.

From manufacturer

Thank you for buying our product. Their reliability has been confirmed in many tests. Reliability of towbar depends also on correct assembly and right operation. For this reasons we kindly ask to read carefully this instruction and apply to hints.

The towbar should be install in points described by a car producer.

The instruction of the assembly

- Reassemble metal or plastic bumper (depending on car version).
NOTE: In the event of metal bumper it is necessary to remove rivets in left and right over wheel.
- Get the muffler lower.
- In rear part make holes (show cuts). You must make way into the chassis members.
- To made holes slide side brackets (pos. 4 and 5) and through holes (pos. A) screw loosely using nuts M8.
- Put the main bar of the towbar (pos. 1) to the chassis members. Holes (pos. B) should agree to factory made holes in chassis members. Fix using bolts M10x40mm (pos. 7) .
NOTE: Before screw from the left side put distance sleeves $\varnothing 25 \times \varnothing 13 \text{mm}$, Length=9mm (pos. 9) from accessories.
- Fix all bolts according to the torque shown in the table.
- Through holes (pos. C) fix the muffler using bolts M8x30mm (pos. 8) from accessories.
- Assemble the bumper. In the event of metal bumper you should rivet it using rivets (pos. 6) from accessories.
- Fix body of the automat and the socket plate (pos. 3). Place tow-ball (pos. 2) according to supplied instruction.
- Connect electric wires of 7-poles socket according to the instruction of the car. (Recommend to make at authorized service station).
- Supplement the paint coating damaged during assembly.

Torque settings for nuts and bolts (8,8):

M6 - 11 Nm	M8 - 25 Nm	M10 - 50 Nm
M12 - 87 Nm	M14 - 138 Nm	M16 - 210 Nm









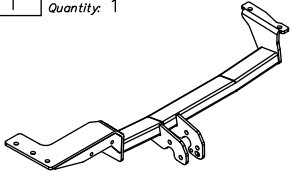
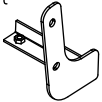

NOTE

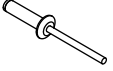
After install the towbar you should get adequate note in registration book (at authorised service station).The car should be equipped with:

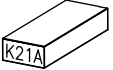
- Indicators
- Tow mirrors

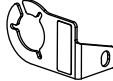
After 1000km of exploitation check all bolts and nuts. The ball of towbar must be always kept clear and conserve with a grease.

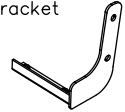
Towbar accessories:

Pos. 1 Name: Main bar Quantity: 1 	Pos. 5 Name: Left bracket Quantity: 1 	Pos. 10 Name: Nut 8 B Quantity: 6 Dim.: M8 
	Pos. 6 Name: Rivet Quantity: 4 	Pos. 11 Name: Plain washer Quantity: 4 Dim.: Ø 10,5 mm 
Pos. 2 Name: Tow ball Quantity: 1 	Pos. 7 Name: Bolt 8,8 B Quantity: 4 Dim.: M10x40mm 	Pos. 12 Name: Plain washer Quantity: 6 Dim.: Ø 8,5 mm 
Pos. 3 Name: Socket plate Quantity: 1 	Pos. 8 Name: Bolt 8,8 B Quantity: 2 Dim.: M8x30mm 	Pos. 13 Name: Spring washer Quantity: 4 Dim.: Ø 10,2 mm 
Pos. 4 Name: Right bracket Quantity: 1 	Pos. 9 Name: Distance sleeve Quantity: 2 Dim.: Ø25xØ13, L=9mm 	Pos. 14 Name: Spring washer Quantity: 6 Dim.: Ø 8,2 mm 



PPUH AUTO-HAK Sp.J.

Produkcja Zaczepów Kulowych
Henryk & Zbigniew Nejman
76-200 SŁUPSK ul. Słoneczna 16K
tel/fax (059) 8-414-414; 8-414-413
E-mail: office@autohak.com.pl
www.autohak.com.pl

Towing hitch (without electrical set)

Class: **A50-X** Cat. no. **K21A**

Designed for:

Manufacturer: **VOLKSWAGEN**

Model: **POLO**

Type: **3/5 doors (6N1)**

produced since 09.1994 till 09.1999

Technical data:

D-value: 6,34 kN

maximum trailer weight: **1200 kg**

maximum vertical cup load: **50 kg**

Approval number acc. to regulations EKG/ONZ 55.01: **E20-55R-01 4512**

Foreword

This towbar is designed according to rules of safety traffic regulations. The towing hitch is a safety component and can be install only by qualified personnel. Any alteration or conversion of the towing hitch is prohibited and would lead to cancellation of design certification. Remove insulating compound and underseal from vehicle (if present) in the area of the matting surfaces of the towing hitch. The vehicle manufacturer's specifications regarding trailer load and max. vertical cup load are decisive for driving, and values for the towing hitch cannot be exceeded.

D-value formula:

$$\frac{\text{Max trailer weight [kg]} \times \text{Max vehicle weight [kg]}}{\text{Max trailer weight [kg]} + \text{Max vehicle weight [kg]}} \times \frac{9,81}{1000} = D \text{ [kN]}$$