

FITTING INSTRUCTION

Clamp mark in acc. with		Cables joining
ISO	PN	
1	L	Left directional lights
2	+	Rear fog lights
3	31	Ground
4	R	Right directional lights
5	58R	Right side parking lights
6	54	Stoplights
7	58L	Left side parking lights

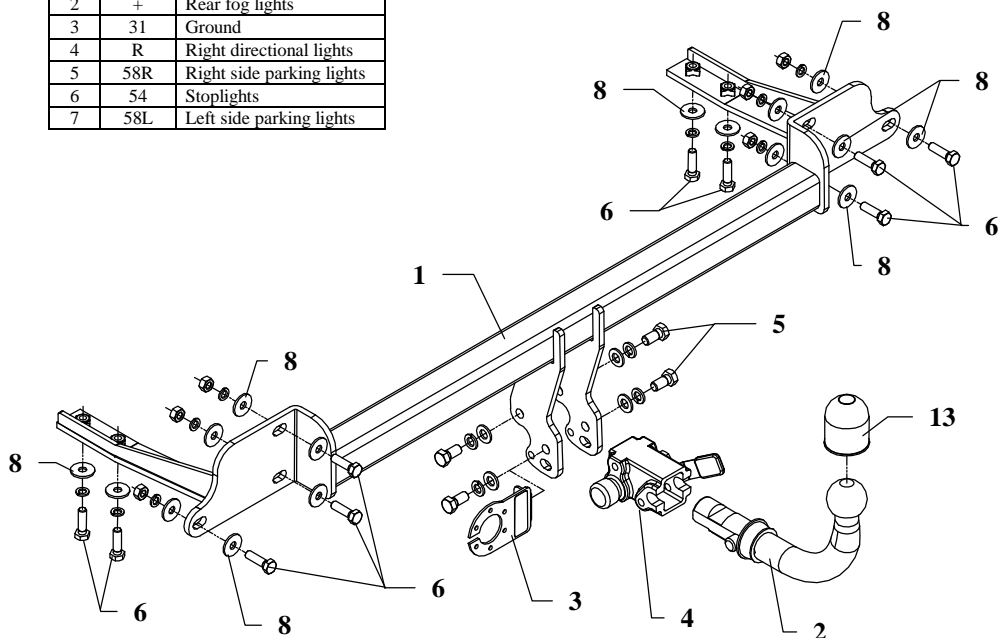

This towbar is designed to assembly in following car:

MAZDA 323 produced since 09.1998 till 12.2001, catalogue no. **M46A** and is prepared to tow trailers max total weight **1600 kg** and max vertical load **75 kg**.

From manufacturer

Thank you for buying our product. Their reliability has been confirmed in many tests. Reliability of towbar depends also on correct assembly and correct exploitation. For this reasons we kindly ask to read carefully this instruction and apply to hints.

The towbar should be install in points described by a car producer.

The instruction of the assembly

1. Disassemble the rear bumper.

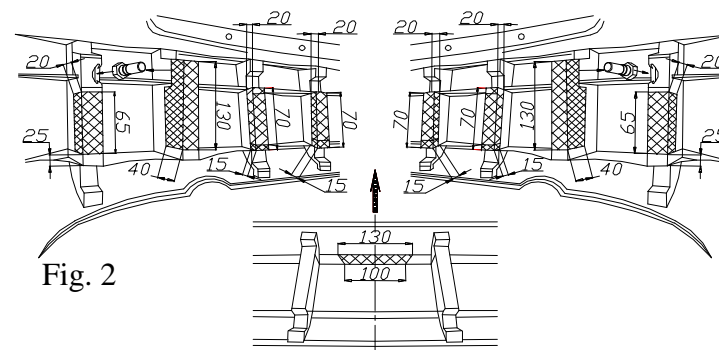

Fig. 2

2. Cut out inside fragments of the bumper according to figure 2.
3. Put main bar of the towbar (pos. 1) into chassis members and fix by bolts M10x35mm (pos. 6), use big washers (pos. 8).
4. Reassemble the bumper.
5. Fix body of the automat (pos. 4) and the socket plate (pos. 3) using bolts M12x25mm (pos. 5) from accessories. Place tow-ball (pos. 2) according to supplied instruction.
6. Tighten all bolts according to the torque shown in the table.
7. Connect electric wires of 7-poles socket according to the instruction of the car. (Recommend to make at authorized service station)
8. Complete paint layer damaged during installation.

Torque settings for nuts and bolts (8,8):

M6 - 11 Nm	M8 - 25 Nm	M10 - 50 Nm
M12 - 87 Nm	M14 - 138 Nm	M16 - 210 Nm









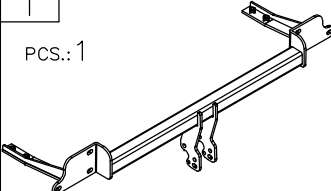

NOTE

After install the towbar you should get adequate note in registration book (at authorised service station).The car should be equipped with:

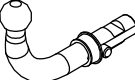
- Indicators
- Tow mirrors

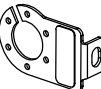
After 1000km check all bolts and nuts. The ball of towbar must be always kept clear and conserve with a grease.

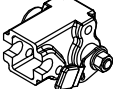
Towbar accessories:

Pos. 1	Main bar 	Pos. 5	Bolt 8,8 B M12x25mm 	Pos. 10	Spring washer ø10,2mm 
PCS.: 1		PCS.: 4		PCS.: 10	
		Pos. 6	Bolt 8,8 B M10x35mm 	Pos. 11	Nut 8 B M10 
		PCS.: 10		PCS.: 6	
Pos. 2	Tow ball 	Pos. 7	Plain washer ø13mm 	Pos. 12	Body plug 
PCS.: 1		PCS.: 4		PCS.: 1	
Pos. 3	Socket plate 	Pos. 8	Plain washer ø30xø10,5x2,5mm 	Pos. 13	Ball cover 
PCS.: 1		PCS.: 16		PCS.: 1	
Pos. 4	Body of the automat 	Pos. 9	Spring washer ø12,2mm 		
PCS.: 1		PCS.: 4			



PPUH AUTO-HAK Sp.J.

Produkcja Zaczepów Kulowych
Henryk & Zbigniew Nejman
76-200 SŁUPSK ul. Słoneczna 16K
tel/fax (059) 8-414-414; 8-414-413
E-mail: office@autohak.com.pl
www. autohak.com.pl

Towing hitch (without electrical set)

Class: **A50-X** Cat. no. **M46A**

Designed for:

Manufacturer: **MAZDA**

Model: **323**

produced since 09.1998 till 12.2001

Technical data:

D-value: 8,2 kg

maximum trailer weight: **1600 kg**

maximum vertical cup load: **75 kg**

Approval number acc. to regulations EKG/ONZ 55.01: E20-55R-01 1789

Foreword

This towing hitch is designed according to rules of safety traffic regulations. The towing hitch is a safety component and can be install only by qualified personnel. Any alteration or conversion of the towing hitch is prohibited and would lead to cancellation of design certification. Remove insulating compound and underseal from vehicle (if present) in the areas of the matting surfaces of the towing hitch.

The vehicle manufacturer's specifications regarding trailer load and max. vertical cup mass are decisive for driving whereat values for the towing hitch cannot be exceeded.

D-value formula:

$$\frac{\text{Max trailer weight [kg]} \times \text{Max vehicle weight [kg]}}{\text{Max trailer weight [kg]} + \text{Max vehicle weight [kg]}} \times \frac{9,81}{1000} = D \text{ [kN]}$$