

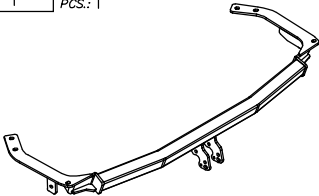

Towing hitch accessories:

Pos. 1	Main bar PCS.: 1	Pos. 4	Distance sleeve PCS.: 2 Ø25xØ13mm L=23mm	Pos. 8	Nut 8 B PCS.: 2 M12
		Pos. 5	Washer PCS.: 2 Ø37xØ13x3mm	Pos. 9	Plain washer PCS.: 8 Ø 13 mm
		Pos. 2	Tow ball (mounting set) PCS.: 1	Pos. 6	Bolt 8,8 B PCS.: 2 M12x60mm
Pos. 3	Socket plate PCS.: 1	Pos. 7	Bolt 8,8 B PCS.: 6 M12x1,25x35mm		
					

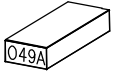
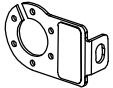
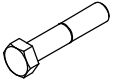

PPUH AUTO-HAK Sp.J.

Produkcja Zaczepów Kulowych
Henryk & Zbigniew Nejman
76-200 SŁUPSK ul. Słoneczna 16K
tel/fax (059) 8-414-414; 8-414-413
E-mail: office@autohak.com.pl
www.autohak.com.pl

Towing hitch (without electrical set)

Class: **A50-X** Cat. no. **O49A**

Designed for:

Manufacturer: **TOYOTA**

Model: **AVENSIS VERSO**

Type: **5 doors**

produced since 08.2001

Technical data:

D-value: 9,7 kN

maximum trailer weight: **1500 kg**

maximum vertical cup mass: **60 kg**

Approval number according to Directive 94/20/EC: e20*94/20*0555*00

Foreword

This towing hitch is designed according to rules of safety traffic regulations. The towing hitch is a safety component and can be installed only by qualified personnel. Any alteration or conversion of the towing hitch is prohibited and would lead to cancellation of design certification. Remove insulating compound and underseal from vehicle (if present) in the area of the mating surfaces of the towing hitch. The vehicle manufacturer's specifications regarding trailer mass and max. vertical cup mass are decisive for driving whereat values for the towing hitch cannot be exceeded.

D-value formula:

$$\frac{\text{Max trailer weight [kg]} \times \text{Max vehicle weight [kg]}}{\text{Max trailer weight [kg]} + \text{Max vehicle weight [kg]}} \times \frac{9,81}{1000} = D \text{ [kN]}$$

FITTING INSTRUCTION

Clamp mark in acc. with		Cables joining
ISO	PN	
1	L	Left directional lights
2	+	Rear fog lights
3	31	Ground
4	R	Right directional lights
5	58R	Right side parking lights
6	54	Stoplights
7	58L	Left side parking lights

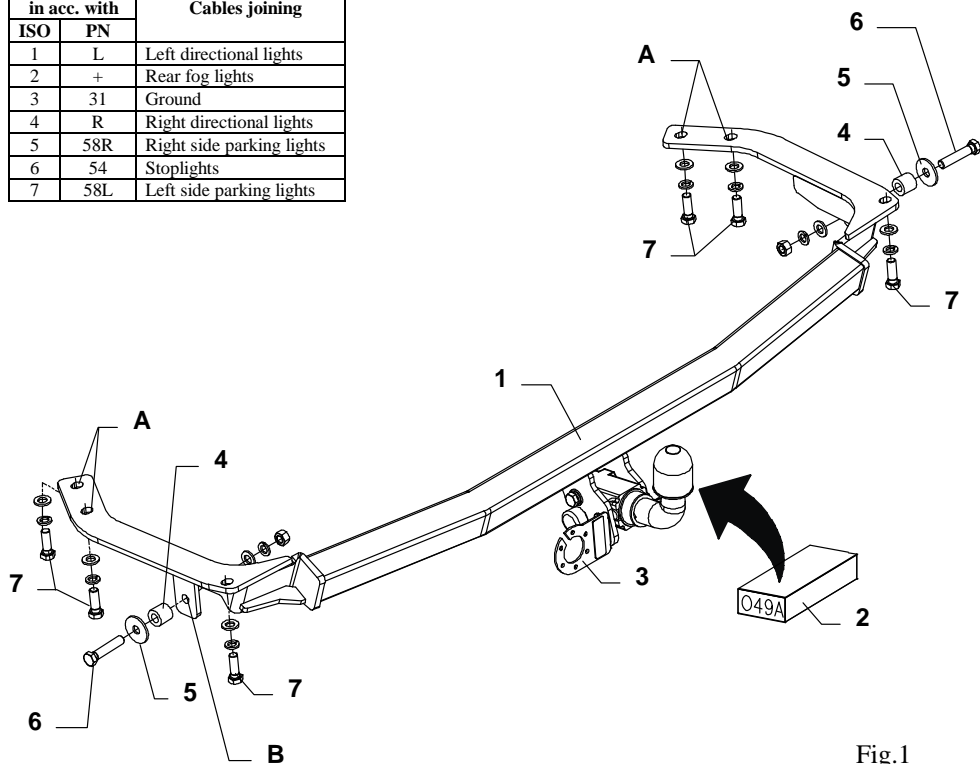

Fig.1

This towbar is designed to assembly in following cars:
TOYOTA AVENSIS VERSO, 5 doors, produced since 08.2001, catalogue no. **O49A** and is prepared to tow trailers max total weight **1500 kg** and max vertical mass **60 kg**.

From manufacturer

Thank you for buying our product. Their reliability has been confirmed in many tests. Reliability of towbar depends also on correct assembly and right operation. For this reasons we kindly ask to read carefully this instruction and apply to hints.

The towbar should be install in points described by a car producer.

The instruction of the assembly

1. Disassemble the bumper.
2. Unscrew the muffler.
3. Apply the main bar of the towbar (pos. 1) to the automobile frame, that way so holes of the towbar (pos. A) be covered with factory-made threaded holes. Fix using bolts M12x1,25x35mm (pos. 7).
4. Through holes (pos. B) fix with factory-made holes. Use distance sleeves $\phi 25 \times \phi 13 \text{mm}$, L=23mm (pos. 4), washers $\phi 37 \times \phi 13 \times 3 \text{mm}$ (pos. 5) and bolts M12x60mm (pos. 6) as showed on the fig. 1.
5. Screw on the muffler.
6. Install the bumper after the previous cut out of its fragment, see fig. 2.

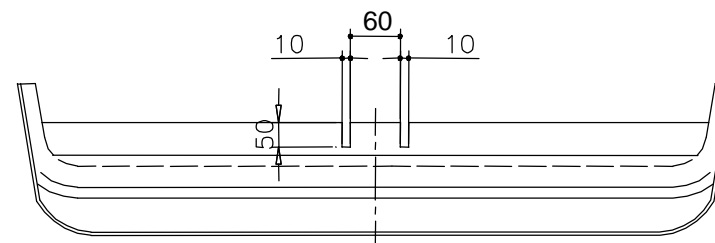

Fig.2

7. Fix body of the automat and place tow-ball according to supplied instruction. Note! Remember to place socket plate (pos. 3) as shown on the drawing 1.
8. Tighten all bolts according to the torque shown in the table.
9. Connect electric wires of 7-poles socket according to the instruction of the car. (Recommend to make at authorized service station).
10. Complete paint layer damaged during installation.

Torque settings for nuts and bolts (8,8):

M6 - 11 Nm	M 8 - 25 Nm	M 10 - 50 Nm
M 12 - 87 Nm	M 14 - 138 Nm	M16 - 210 Nm

NOTE

After installation of a towing hitch you should get adequate note in registration book (at authorised service station). The car should be equipped with:

- Indicators
- Tow mirrors

After 1000km of exploitation check all bolts and nuts. The ball of towing hitch must be always kept clear and conserve with a grease.