

## FITTING INSTRUCTION

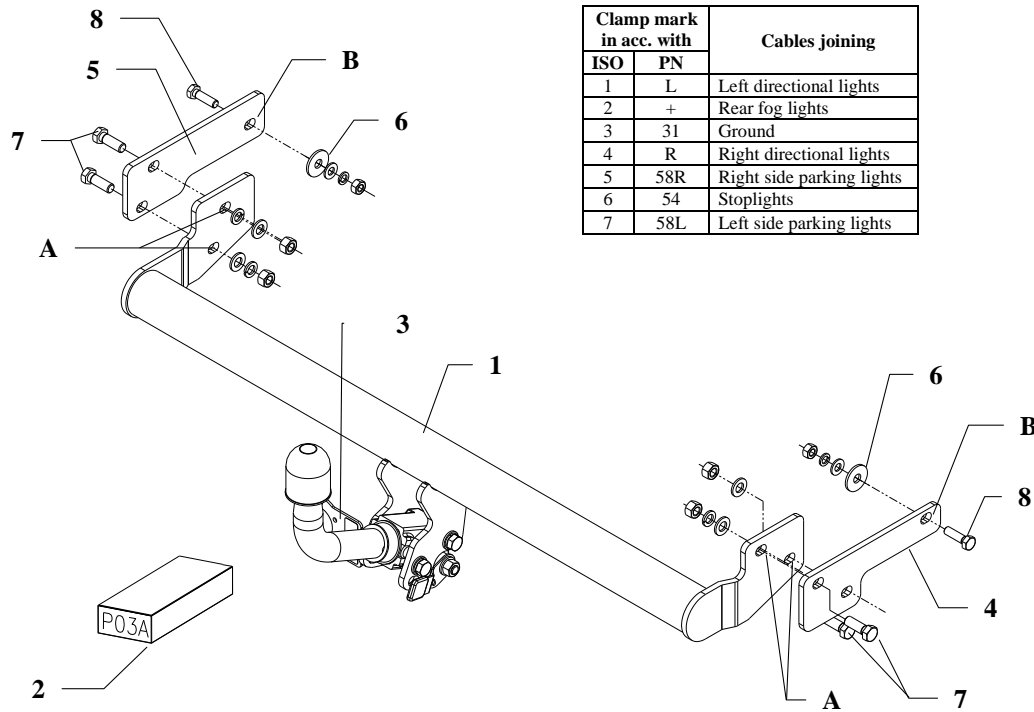

Clamp mark in acc. with		Cables joining
ISO	PN	
1	L	Left directional lights
2	+	Rear fog lights
3	31	Ground
4	R	Right directional lights
5	58R	Right side parking lights
6	54	Stoptlights
7	58L	Left side parking lights

This towbar is designed to assembly in following car:  
**CITROEN ZX 3/5 DOORS (N2)**, produced since 03.1991 till 06.1997,  
 catalogue number **P03A**, and is prepared to tow trailers max total weight  
**1100 kg** and max vertical load **70 kg**.

### *From manufacturer*

Thank you for buying our product. Their reliability has been confirmed in many tests. Reliability of towbar depends also on correct assembly and right operation. For this reasons we kindly ask to read carefully this instruction and apply to hints.

*The towbar should be install in points described by a car producer.*

## Fitting instructions

1. Get lower the wheel cover and take out the spare wheel.
2. Between original tow handles put side brackets pos. 4 and 5 and main bar of the towbar (pos. 1) and next through existing holes and holes pos. A fix all using bolts M12x35mm (pos. 7).
3. Through holes (pos. B) drill the car construction using bit  $\varnothing 11\text{mm}$ , next fix with bolts M10x35mm pos. 8 ( use big washers – pos. 6).
4. Fix body of the automat and place tow-ball according to supplied instruction. Note! Remember to place socket plate (pos. 3) as shown on the drawing 1.
5. Tighten all bolts according to the torque shown in the table.
6. Connect electric wires according to the instruction of the car. (Recommend to make at authorized service station)
7. Supplement the paint coating damaged during assembly.

Torque settings for nuts and bolts (8,8):

<b>M 8</b>	25 Nm	<b>M 10</b>	55 Nm
<b>M 12</b>	85 Nm	<b>M 14</b>	135Nm



### NOTE

After install the towbar you should get adequate registration in registration book (at authorised service station).The car should be equipment with:

- Indicators
- Tow mirrors

After 1000km check all bolts and nuts. The ball of towbar must be always kept clear and conserve with a grease.

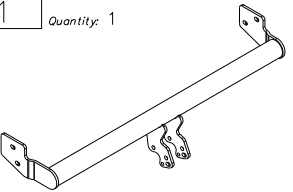
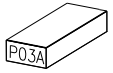
## Towbar accessories:

Pos. 1 Name: Main bar Quantity: 1	Pos. 6 Name: Washer Quantity: 2 Dim.: Ø35xØ12x3mm	Pos. 12 Name: Plain washer Quantity: 2 Dim.: Ø 10,5 mm
	Pos. 7 Name: Bolt 8,8 B Quantity: 4 Dim.: M12x35mm	Pos. 13 Name: Spring washer Quantity: 4 Dim.: Ø 12,2 mm
Pos. 2 Name: Tow ball Quantity: 1	Pos. 8 Name: Bolt 8,8 B Quantity: 2 Dim.: M10x35mm	Pos. 14 Name: Spring washer Quantity: 2 Dim.: Ø 10,2 mm
	Pos. 9 Name: Nut 8 B Quantity: 4 Dim.: M12	Pos. 15 Name: Ball cover Quantity: 1
Pos. 3 Name: Socket plate Quantity: 1	Pos. 10 Name: Nut 8 B Quantity: 2 Dim.: M10	
Pos. 4 Name: Right bracket Quantity: 1	Pos. 11 Name: Plain washer Quantity: 4 Dim.: Ø 13 mm	
Pos. 5 Name: Left bracket Quantity: 1		



**PPUH AUTO-HAK S.J.**

Produkcja Haków Holowniczych  
Henryk & Zbigniew Nejman  
76-200 SŁUPSK ul. Słoneczna 16K  
tel/fax (059) 8-414-414; 8-414-413  
E-mail: [office@autohak.com.pl](mailto:office@autohak.com.pl)  
[www.autohak.com.pl](http://www.autohak.com.pl)

## Towing hitch (without electrical set)

Class: **A50-X** Cat. no. **P03A**

Designed for:

Manufacturer: **CITROEN**

Model: **ZX**

Type: **3/5 doors (N2)**

produced since 03.1991 till 06.1997

Technical data:

**D-value: 6,46 kN**

maximum trailer weight: **1100 kg**

maximum vertical cup load: **70 kg**

Approval number according to Directive 94/20/EC: **e20\*94/20\*0796\*00**

## Foreword

This towbar is designed according to rules of safety traffic regulations. The towing hitch is a safety component and must be installed only by qualified personnel. Any alteration or conversion to the towinh hitch is prohibited and would lead to cancellation of design certification. Remove insulating compound and underseal from vehicle (if present) in the area of the matting surfaces of the towing hitch.

The vehicle manufacturer's specifications regarding trailer load and max. vertical cup load are decisive for driving, and values for the towing hitch cannot be exceeded.

*D-value formula:*

$$\frac{\text{Max trailer weight [kg]} \times \text{Max vehicle weight [kg]}}{\text{Max trailer weight [kg]} + \text{Max vehicle weight [kg]}} \times \frac{9,81}{1000} = D \text{ [kN]}$$