

FITTING INSTRUCTION

| Clamp mark in acc. with | | Cables joining |
|-------------------------|-----|---------------------------|
| ISO | PN | |
| 1 | L | Left directional lights |
| 2 | + | Rear fog lights |
| 3 | 31 | Ground |
| 4 | R | Right directional lights |
| 5 | 58R | Right side parking lights |
| 6 | 54 | Stoplights |
| 7 | 58L | Left side parking lights |

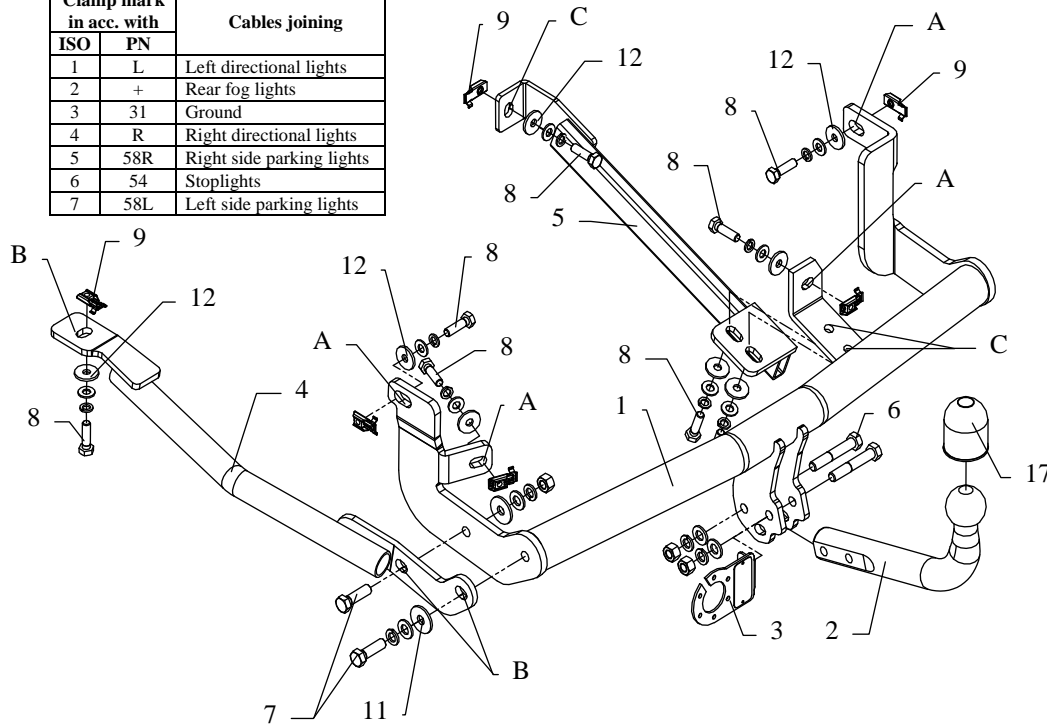

This towbar is designed to assembly in following cars:

PEUGEOT

806, 5 doors, VAN, produced since 06.1994 till 08.2002

Expert I, metal built-up, VAN, produced since 02.1996 till 01.2007

CITROEN

Evasion, 5 doors, VAN, produced since 06.1994 till 08.2002

Jumpy I, metal built-up, VAN, produced since 09.1994 till 0.2007

FIAT

Scudo I, metal built-up, VAN (220P), produced since 02.1996 till 01.2007

Ulysse, Lancia Z, 5 doors, VAN, (220/2), produced since 1994 till 08.2002

catalogue number **R17** and is prepared to tow trailers max total weight **1800 kg** and max vertical mass **80 kg**.

From manufacturer

Thank you for buying our product. Their reliability has been confirmed in many tests. Reliability of towbar depends also on correct assembly and correct exploitation. For this reasons we kindly ask to read carefully this instruction and apply to hints.

The towbar should be install in points described by a car producer.

The instruction of the assembly

1. Get lower a spare wheel and exhaust manifold.
2. Make opening in the bumper (in axis): width 50mm, depth 50mm.
3. Put caget nuts (pos. 9) to the chassis members.
4. Fix main bar of the towbar (pos. 1) to chassis members at points A – loosely.
5. Fix side bracket (pos. 4) to the chassis member and to the main bar of the towbar at points B – loosely.
6. Fix central bracket (pos. 5) to the chassis member and to the main bar of the towbar at points C – loosely.
7. Fix tow-ball (pos. 2) and socket plate (pos. 3) using bolts M12x75mm (pos. 6) from accessories.
8. Fix tight all bolts according to the torque shown in the table.
9. Connect electric wires according to the instruction of the car. (Recommend to make at authorized service station)
10. Complete the paint coating damaged during installation.

Torque settings for nuts and bolts (8,8):

| | | |
|--------------------|---------------------|---------------------|
| M6 - 11 Nm | M8 - 25 Nm | M10 - 50 Nm |
| M12 - 87 Nm | M14 - 138 Nm | M16 - 210 Nm |











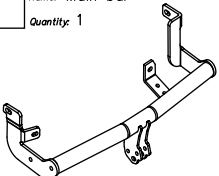
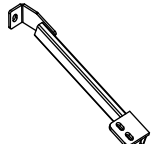

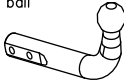
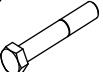

NOTE

After install the towbar you should get adequate note in registration book (at authorised service station).The car should be equipped with:

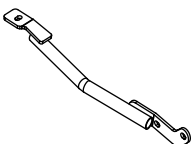
- Indicators
- Tow mirrors

After **1000km** of exploitation check all bolts and nuts. The ball of towbar must be always kept clear and conserve with a grease.

Towbar accessories:

| | | | |
|--|--|---|--|
| Pos. 1 Name: Main bar Quantity: 1  | Pos. 5 Name: Central bracket Quantity: 1  | Pos. 10 Name: Nut 8 B Quantity: 3 Dim.: M12  | Pos. 16 Name: Spring washer Quantity: 8 Dim.: Ø 10,2 mm  |
| Pos. 2 Name: Tow ball Quantity: 1  | Pos. 6 Name: Bolt 8,8 B Quantity: 2 Dim.: M12x75mm  | Pos. 11 Name: Washer Quantity: 2 Dim.: Ø35xØ12x3mm  | Pos. 17 Name: Ball cover Quantity: 1  |
| Pos. 3 Name: Socket plate Quantity: 1  | Pos. 7 Name: Bolt 8,8 B Quantity: 2 Dim.: M12x40mm  | Pos. 12 Name: Washer Quantity: 8 Dim.: Ø30xØ10x3mm  | |
| Pos. 4 Name: Left bracket Quantity: 1  | Pos. 8 Name: Bolt 8,8 B Quantity: 8 Dim.: M10x35mm  | Pos. 13 Name: Plain washer Quantity: 4 Dim.: Ø 13 mm  | |
| | Pos. 9 Name: Cagel nut Quantity: 6 Dim.: M10  | Pos. 14 Name: Plain washer Quantity: 8 Dim.: Ø 10,5 mm  | |
| | | Pos. 15 Name: Spring washer Quantity: 4 Dim.: Ø 12,2 mm  | |



PPUH AUTO-HAK Sp.J.

Produkcja Zaczepów Kulowych
Henryk & Zbigniew Nejman
76-200 SŁUPSK ul. Słoneczna 16K
tel/fax (059) 8-414-414; 8-414-413
E-mail: office@autohak.com.pl
www. autohak.com.pl

Towing hitch (without electrical set)

Class: **A50-X** Cat. no. **R17**

Designed for:

PEUGEOT

- ✓ **806, 5 doors, VAN**
produced since 06.1994 till 08.2002
- ✓ **Expert I, metal built-up, VAN**
produced since 02.1996 till 01.2007

CITROEN

- ✓ **Evasion, 5 doors, VAN**
produced since 06.1994 till 08.2002
- ✓ **Jumpy I, metal built-up, VAN**
produced since 09.1994 till 0.2007

FIAT

- ✓ **Scudo I, metal built-up, VAN (220P)**
produced since 02.1996 till 01.2007
- ✓ **Ulysse, Lancia Z, 5 doors, VAN, (220/2)**
produced since 1994 till 08.2002

Technical data:

D-value: 10,2 kN

maximum trailer weight: **1800 kg**

maximum vertical cup mass: **80 kg**

Approval number acc. to regulations EKG/ONZ 55.01: E20-55R-01-1110

Foreword

This towbar is designed according to rules of safety traffic regulations. The towing hitch is a safety component and can be install only by qualified personnel. Any alteration or conversion of the towing hitch is prohibited and would lead to cancellation of design certification. Remove insulating compound and underseal from vehicle (if present) in the area of the matting surfaces of the towing hitch.

The vehicle manufacturer's specifications regarding trailer load and max. vertical cup load are decisive for driving, and values for the towing hitch cannot be exceeded.

D-value formula:

$$\frac{\text{Max trailer weight [kg]} \times \text{Max vehicle weight [kg]}}{\text{Max trailer weight [kg]} + \text{Max vehicle weight [kg]}} \times \frac{9,81}{1000} = D \text{ [kN]}$$