

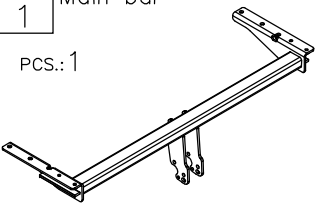







Towing hitch accessories:

Pos. 1 Main bar PCS.: 1		Pos. 4 Bolt 8.8 B M12x35mm PCS.: 6		Pos. 8 Washer ø8,5mm PCS.: 4	
		Pos. 5 Bolt 8.8 B M8x25mm PCS.: 4		Pos. 9 Spring washer ø12,2mm PCS.: 6	
Pos. 2 Tow ball (mounting set) PCS.: 1		Pos. 6 Washer ø37xø13x3mm PCS.: 4		Pos. 10 Spring washer ø8,2mm PCS.: 4	
Pos. 3 Socket plate PCS.: 1		Pos. 7 Washer ø13mm PCS.: 2			

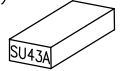

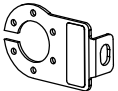
PPUH AUTO-HAK Sp.J.

Produkcja Zaczepów Kulowych
Henryk & Zbigniew Nejman
76-200 SŁUPSK ul. Słoneczna 16K
tel/fax (059) 8-414-414; 8-414-413
E-mail: office@autohak.com.pl
www.autohak.com.pl

Towing hitch (without electrical set)

Class: **A50-X** Cat. no. **SU43A**

Designed for:

Manufacturer: **SUBARU**

Model: **LEGACY OUTBACK**

Type: **ESTATE, BE/BH**

produced since 10.1998 till 10.2003

Technical data:

D-value: 10,5 kN

maximum trailer weight: **1800 kg**

maximum vertical cup mass: **75 kg**

Approval number according to Directive 94/20/EC: e20*94/20*0641*00

Foreword

This towing hitch is designed according to rules of safety traffic regulations. The towing hitch is a safety component and can be install only by qualified personnel. Any alteration or conversion of the towing hitch is prohibited and would lead to cancellation of design certification. Remove insulating compound and underseal from vehicle (if present) in the area of the matting surfaces of the towing hitch. The vehicle manufacturer's specifications regarding trailer load and max. vertical cup load are decisive for driving whereat values for the towing hitch cannot be exceeded.

D-value formula:

$$\frac{\text{Max trailer weight [kg]} \times \text{Max vehicle weight [kg]}}{\text{Max trailer weight [kg]} + \text{Max vehicle weight [kg]}} \times \frac{9,81}{1000} = D \text{ [kN]}$$

FITTING INSTRUCTION

Clamp mark in acc. with		Cables joining
ISO	PN	
1	L	Left directional lights
2	+	Rear fog lights
3	31	Ground
4	R	Right directional lights
5	58R	Right side parking lights
6	54	Stoptlights
7	58L	Left side parking lights

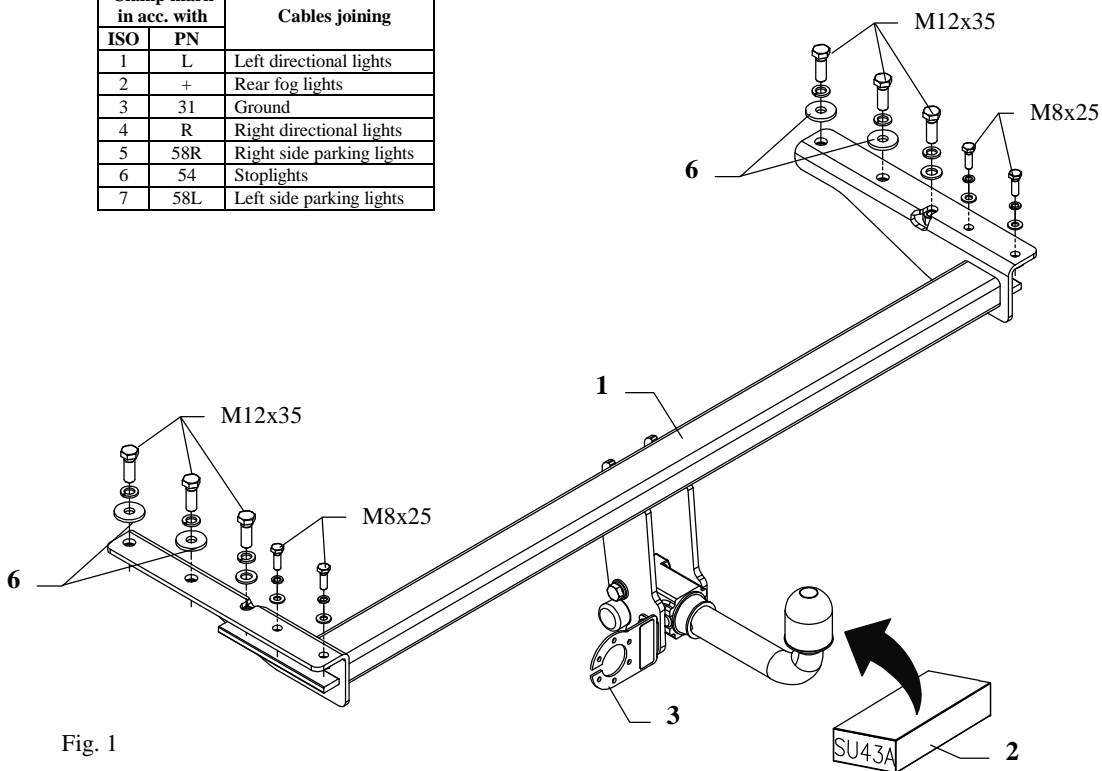

Fig. 1

This towing hitch is designed to assembly in following cars: **SUBARU LEGACY OUTBACK, Estate, type BE/BH**, produced since 10.1998 till 10.2003, catalogue no. **SU43A** and is prepared to tow trailers max total weight **1800 kg** and max vertical mass **75 kg**.

From manufacturer

Thank you for buying our product. Their reliability has been confirmed in many tests. Reliability of towing hitch depends also on correct assembly and right operation. For this reasons we kindly ask to read carefully this instruction and apply to hints.

The towing hitch should be install in points described by a car producer.

The instruction of the assembly

1. Disassemble the bumper together with his metal fulfilment.
2. Unscrew the metal fulfilment from the bumper.
3. Cut out the fragment 90x80mm in the plastic canopy (in the axis of the bumper).
4. Disconnect the metal fulfilment as showed on the fig. 2.
5. Element B (see fig. 2) not used anymore, whereas element A (see fig. 2) one ought to fix to the main bar of the towing hitch (see fig. 1, pos. 1) using bolts M8x25mm (pos. 5) as showed on the fig. 2.
6. So prepared towing hitch fix with the bumper, which one ought to slip into chassis members, then fix using bolts M12x35mm (pos. 4) as showed on the fig.
7. Tighten all bolts according to the torque shown in the table.
8. Fix body of the automat and place tow-ball according to supplied instruction. Note! Remember to place socket plate (pos. 3) as shown on the drawing 1.
9. Connect electric wires of 7-poles socket according to the instruction of the car. (Recommend to make at authorized service station).
10. Complete paint layer damaged during installation.

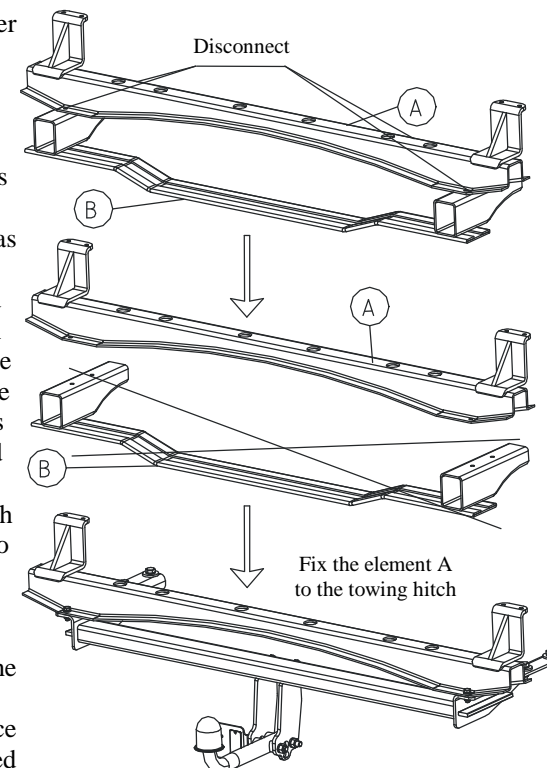

Fig. 2

Torque settings for nuts and bolts (8,8):	
M 8 - 25 Nm	M 10 - 55 Nm
M 12 - 85 Nm	M 14 - 135 Nm

NOTE

After install the towing hitch you should get adequate note in registration book (at authorised service station).The car should be equipped with:

- Indicators
- Tow mirrors

After 1000km of exploitation check all bolts and nuts. The ball of towing hitch must be always kept clear and conserve with a grease.