

FITTING INSTRUCTION

Clamp mark in acc. with		Cables joining
ISO	PN	
1	L	Left directional lights
2	+	Rear fog lights
3	31	Ground
4	R	Right directional lights
5	58R	Right side parking lights
6	54	Stoplights
7	58L	Left side parking lights

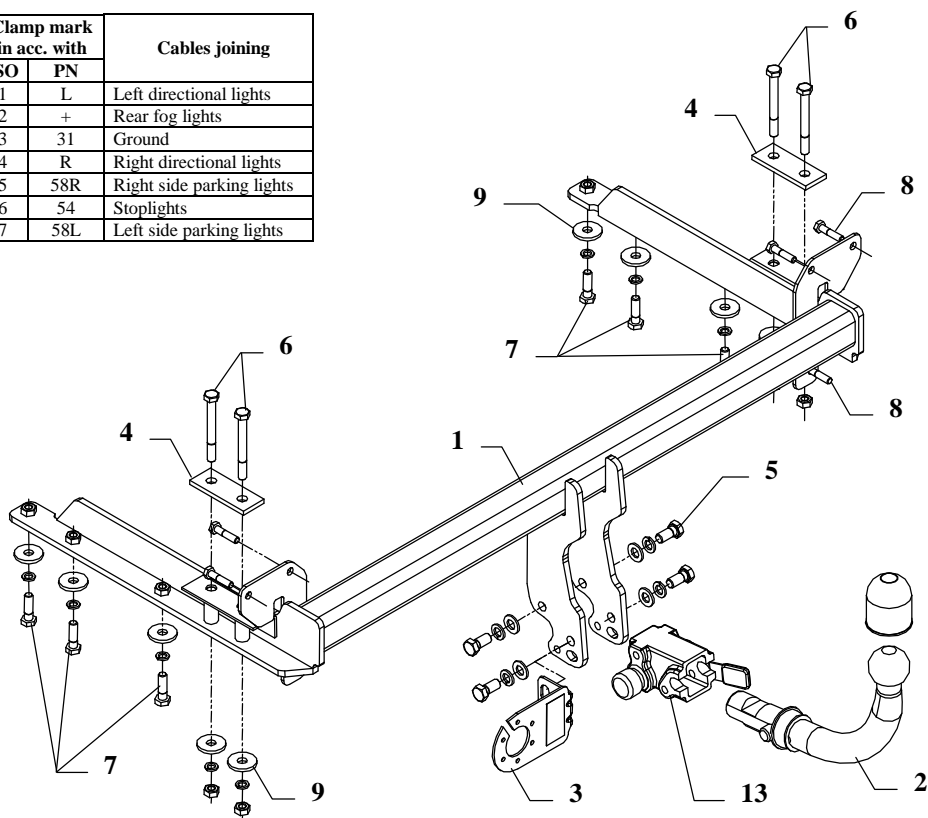

This towbar is designed to assembly in following cars:
KIA SEPHIA II, KIA SHUMA II, produced since 1998 till 04.2001,
 catalogue no. **T06A** and is prepared to tow trailers max total weight
1350 kg and max vertical load **50 kg**.

From manufacturer

Thank you for buying our product. Their reliability has been confirmed in many tests. Reliability of towbar depends also on correct assembly and right operation. For this reasons we kindly ask to read carefully this instruction and apply to hints.

The towbar should be install in points described by a car producer.

The instruction of the assembly

- Disassemble:
 - plastic, side covers in the trunk,
 - the bumper.
 From bumper remove plastic „gutter” and handles. Handles not used any more.
- Plastic „gutter” fix to main bar of the towbar (pos. 1) with bolts M8x35mm – pos. 8 (use original nuts).
- So prepared towbar slip to chassis members and screw using bolts from accessories as shown in the drawing.
- Assemble the bumper after cut out fragment 80x20mm in bottom part, fulfilment too.
- Fix body of the automat (pos. 13) and the socket plate (pos. 3) using bolts M12x25mm (pos. 5) from accessories. Place tow-ball (pos. 2) according to supplied instruction.
- Tighten all bolts according to the torque shown in the table.
- Connect electric wires of 7-poles socket according to the instruction of the car. (Recommend to make at authorized service station).
- Complete paint layer damaged during installation.

Torque settings for nuts and bolts (8,8):

M6 - 11 Nm	M8 - 25 Nm	M10 - 50 Nm
M12 - 87 Nm	M14 - 138 Nm	M16 - 210 Nm

NOTE

After install the towbar you should get adequate note in registration book (at authorised service station).The car should be equipped with:

- Indicators
- Tow mirrors

After 1000km of exploitation check all bolts and nuts. The ball of towbar must be always kept clear and conserve with a grease.

Towbar accessories:

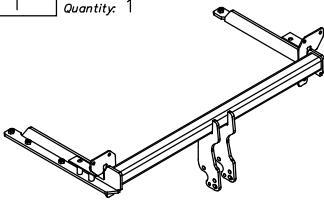
Pos. 1	Name: Main bar Quantity: 1	Pos. 6	Name: Bolt 8,8 B Quantity: 4 Dim.: M10x90mm	Pos. 12	Name: Spring washer Quantity: 10 Dim.: Ø 10,2 mm
		Pos. 7	Name: Bolt 8,8 B Quantity: 6 Dim.: M10x35mm	Pos. 13	Name: Body of the automat Quantity: 1
Pos. 2	Name: Tow ball Quantity: 1	Pos. 8	Name: Bolt 8,8 B Quantity: 6 Dim.: M8x35mm	Pos. 14	Name: Nut 8 B Quantity: 4 Dim.: M10
Pos. 3	Name: Socket plate Quantity: 1	Pos. 9	Name: Washer Quantity: 10 Dim.: Ø35xØ12x4mm	Pos. 15	Name: Ball cover Quantity: 1
Pos. 4	Name: Plate Quantity: 2	Pos. 10	Name: Plain washer Quantity: 4 Dim.: Ø 13 mm	Pos. 16	Name: Body plug Quantity: 1
Pos. 5	Name: Bolt 8,8 B Quantity: 4 Dim.: M12x25mm	Pos. 11	Name: Spring washer Quantity: 4 Dim.: Ø 12,2 mm		



PPUH AUTO-HAK S.J.

Produkcja Zaczepów Kulowych
Henryk & Zbigniew Nejman
76-200 SŁUPSK ul. Słoneczna 16K
tel/fax (059) 8-414-414; 8-414-413
email: office@autohak.com.pl
www.autohak.com.pl

Towing hitch (without electrical set)

Class: **A50-X** Cat. no. **T06A**

Designed for:

Manufacturer: **KIA**

Model: **SEPHIA II**

Type: **4 doors**

Model: **SHUMA II**

Type: **5 doors**

both produced since 1998 till 04.2001

Approval number according to Directive 94/20/EC: **e20*94/20*1022*00**

Technical data:

D-value: 7,6 kN

maximum trailer weight: **1350 kg**

maximum vertical cup load: **50 kg**

Foreword

This towbar is designed according to rules of safety traffic regulations. The towing hitch is a safety component and can be install only by qualified personnel. Any alteration or conversion of the towing hitch is prohibited and would lead to cancellation of design certification. Remove insulating compound and underseal from vehicle (if present) in the area of the matting surfaces of the towing hitch.

The vehicle manufacturer's specifications regarding trailer load and max. vertical cup load are decisive for driving, and values for the towing hitch cannot be exceeded.

D-value formula:

$$\frac{\text{Max trailer weight [kg]} \times \text{Max vehicle weight [kg]}}{\text{Max trailer weight [kg]} + \text{Max vehicle weight [kg]}} \times \frac{9,81}{1000} = D \text{ [kN]}$$