

FITTING INSTRUCTION

Clamp mark in acc. with		Cables joining
ISO	PN	
1	L	Left directional lights
2	+	Rear fog lights
3	31	Ground
4	R	Right directional lights
5	58R	Right side parking lights
6	54	Stoplights
7	58L	Left side parking lights

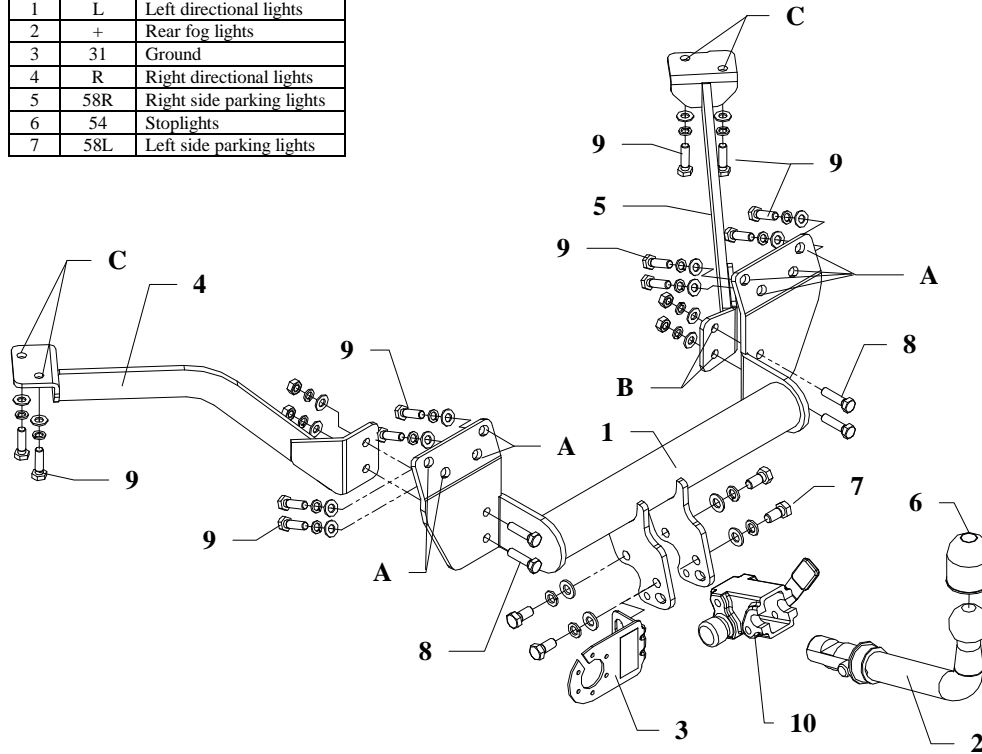

Fig. 1

This towbar is designed to assembly in following cars:
NISSAN VANETTE CARGO produced since 1995, catalogue no. **V58A**
 and is prepared to tow trailers max total weight **1600 kg** and max vertical load **80 kg**.

From manufacturer

Thank you for buying our product. Their reliability has been confirmed in many tests. Reliability of towbar depends also on correct assembly and right exploit. For this reasons we kindly ask to read carefully this instruction and apply to hints.

The towbar should be install in points described by a car producer.

Fitting instruction

1. Put main bar of towbar (pos. 1) to rear part of the car in this way so holes (pos. A) agree with original threaded holes and screw all using bolts M10x1,25x35mm (pos. 9).
2. Element (pos. 4) put to towbar (left side) in this way, so holes (pos. B) agree with holes in towbar and holes (pos. C) agree with original threaded holes in chassis member and screw using bolts – see drawing.
3. Element (pos. 5) put to towbar (right side) and screw as described in point 2.
4. Tighten all bolts according to the torque shown in the table.
5. Fix body of the automat (pos. 10) and the socket plate (pos. 3) using bolts M12x25mm (pos. 7) from accessories. Place tow-ball (pos. 2) according to supplied instruction.
6. Connect electric wires of 7-poles socket according to the instruction of the car. (Recommend to make at authorized service station)
7. Complete the paint coating damaged during installation.

Torque settings for nuts and bolts (8,8):

M 8 25 Nm

M 10 55 Nm

M 12 85 Nm

M 14 135 Nm









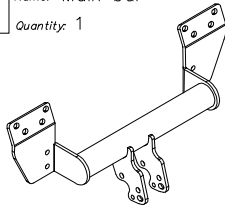
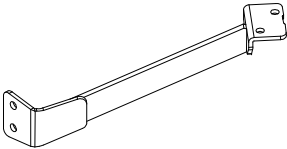
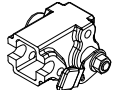
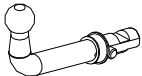

NOTE

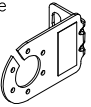
After install the towbar you should get adequate registration in registration book (at authorised service station).The car should be equipped with:

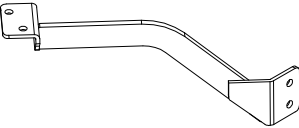
- Indicators
- Tow mirrors

After 1000km check all bolts and nuts. The ball of towbar must be always kept clear and conserve with a grease.

Towbar accessories:

Pos. 1 Name: Main bar Quantity: 1	Pos. 5 Name: Right bracket Quantity: 1	Pos. 10 Name: Body of the automat Quantity: 1
		
Pos. 2 Name: Tow ball Quantity: 1	Pos. 6 Name: Ball cover Quantity: 1	Pos. 11 Name: Nut 8 B Quantity: 4 Dim.: M10
		
Pos. 3 Name: Socket plate Quantity: 1	Pos. 7 Name: Bolt 8,8 B Quantity: 4 Dim.: M12x25mm	Pos. 12 Name: Plain washer Quantity: 2 Dim.: Ø13mm
		
Pos. 4 Name: Left bracket Quantity: 1	Pos. 8 Name: Bolt 8,8 B Quantity: 4 Dim.: M10x40mm	Pos. 13 Name: Plain washer Quantity: 16 Dim.: Ø12,5mm
		
	Pos. 9 Name: Bolt 8,8 B Quantity: 12 Dim.: M10x1,25x35mm	Pos. 14 Name: Spring washer Quantity: 2 Dim.: Ø12,2mm
		
		Pos. 15 Name: Spring washer Quantity: 16 Dim.: Ø10,2mm
		
		Pos. 16 Name: Body plug Quantity: 1
		



PPUH AUTO-HAK S.J.

Produkcja Haków Holowniczych
Henryk & Zbigniew Nejman
76-200 SŁUPSK ul. Słoneczna 16K
tel/fax (059) 8-414-414; 8-414-413
E-mail: office@autohak.com.pl
www. autohak.com.pl

Towing hitch (without electrical set)

Class: **A50-X** Cat. no. **V58A**

Designed for:

Manufacturer: **NISSAN**

Model: **VANETTE CARGO**

produced since 1995

Technical data:

D-value: 9,7 kN

maximum trailer weight: **1600 kg**

maximum vertical cup load: **80 kg**

Approval number according to Directive 94/20/EC: **e20*94/20*1070*00**

Foreword

This towbar is design according to rules of safety traffic regulations. The towing hitch is a safety component and must be installed only by qualified personnel. Any alteration or conversion to the towinh hitch is prohibited and would lead to cancellation of design certification. Remove insulating compound and underseal from vehicle (if present) in the area of the matting surfaces of the towing hitch. The vehicle manufacturer's specifications regarding trailer load and max. vertical cup load are decisive for driving, and values for the towing hitch must not be exceeded.

D-value formula:

$$\frac{\text{Max trailer weight [kg]} \times \text{Max vehicle weight [kg]}}{\text{Max trailer weight [kg]} + \text{Max vehicle weight [kg]}} \times \frac{9,81}{1000} = D \text{ [kN]}$$