

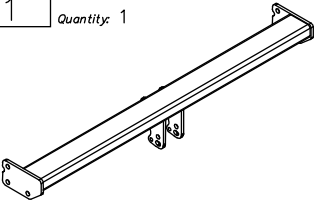

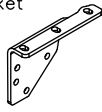







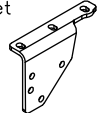

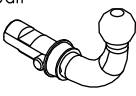
## Towbar accessories:

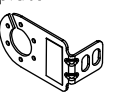
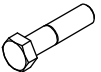
Pos. 1	Name: Main bar Quantity: 1	Pos. 5	Name: Right bracket Quantity: 1	Pos. 11	Name: Nut 8 B Quantity: 8 Dim.: M12
					
		Pos. 6	Name: Left bracket Quantity: 1	Pos. 12	Name: Plain washer Quantity: 22 Dim.: Ø 13 mm
					
Pos. 2	Name: Tow ball Quantity: 1	Pos. 7	Name: Bolt 8,8 B Quantity: 4 Dim.: M12x25mm	Pos. 13	Name: Spring washer Quantity: 22 Dim.: Ø 12,2 mm
					
Pos. 3	Name: Socket plate Quantity: 1	Pos. 8	Name: Bolt 8,8 B Quantity: 2 Dim.: M12x45mm	Pos. 14	Name: Ball cover Quantity: 1
					
Pos. 4	Name: Plate Quantity: 2	Pos. 9	Name: Bolt 8,8 B Quantity: 6 Dim.: M12x40mm	Pos. 15	Name: Body of the automat Quantity: 1
					
		Pos. 10	Name: Bolt 8,8 B Quantity: 10 Dim.: M12x1,25x40mm	Pos. 16	Name: Body plug Quantity: 1
					

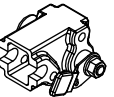

## PPUH AUTO-HAK Sp.J.

Produkcja Zaczepów Kulowych  
Henryk & Zbigniew Nejman  
76-200 SŁUPSK ul. Słoneczna 16K  
tel/fax (059) 8-414-414; 8-414-413  
E-mail: [office@autohak.com.pl](mailto:office@autohak.com.pl)  
[www.autohak.com.pl](http://www.autohak.com.pl)

### Towing hitch (without electrical set)

Class: **A50-X** Cat. no. **V63A**

Designed for:

Manufacturer: **NISSAN**

Model: **NAVARA (D40)**

**with tubular bumper**

produced since 05.2005 till 03.2016

Technical data:

**D-value: 14,5 kN**

maximum trailer weight: **3000 kg**

maximum vertical cup load: **120 kg**

Approval number according to Directive 94/20/EC: **e20\*94/20\*0094\*00**

### Foreword

This towbar is designed according to rules of safety traffic regulations. The towing hitch is a safety component and can be install only by qualified personnel. Any alteration or conversion of the towing hitch is prohibited and would lead to cancellation of design certification. Remove insulating compound and underseal from vehicle (if present) in the area of the matting surfaces of the towing hitch. The vehicle manufacturer's specifications regarding trailer load and max. vertical cup load are decisive for driving whereat values for the towing hitch cannot be exceeded.

*D-value formula:*

$$\frac{\text{Max trailer weight [kg]} \times \text{Max vehicle weight [kg]}}{\text{Max trailer weight [kg]} + \text{Max vehicle weight [kg]}} \times \frac{9,81}{1000} = D \text{ [kN]}$$

## FITTING INSTRUCTION

Clamp mark in acc. with		Cables joining
ISO	PN	
1	L	Left directional lights
2	+	Rear fog lights
3	31	Ground
4	R	Right directional lights
5	58R	Right side parking lights
6	54	Stoptlights
7	58L	Left side parking lights

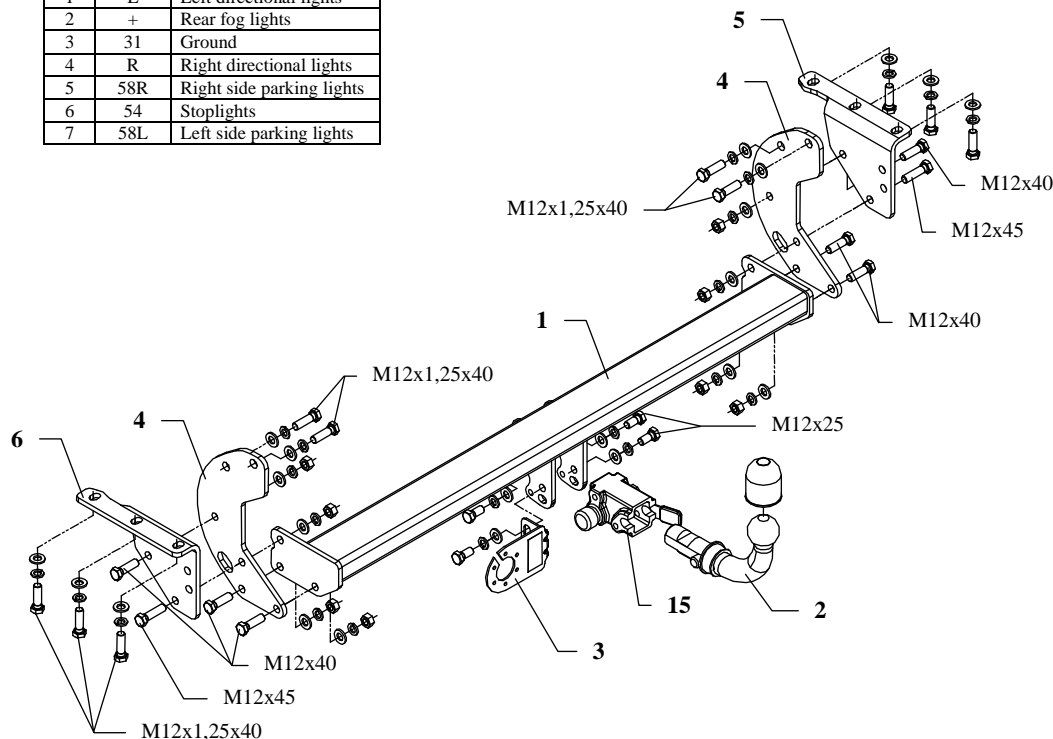

This towbar is designed to assembly in following cars:  
**NISSAN NAVARA (D40) with tubular bumper**, produced since 05.2005 till 03.2016, catalogue no. **V63A** and is prepared to tow trailers max total weight **3000 kg** and max vertical load **120 kg**.

### *From manufacturer*

Thank you for buying our product. Their reliability has been confirmed in many tests. Reliability of towbar depends also on correct assembly and right operation. For this reasons we kindly ask to read carefully this instruction and apply to hints.

*The towbar should be install in points described by a car producer.*

## The instruction of the assembly

1. For the purpose of installings of the towbar one ought to disassemble the bumper (tubular) and its handles which will not be assembled again.
2. From the right and left side of the frame fix plates (pos. 4) and side brackets (pos. 5 and 6) using bolts M12x1,25x40mm (pos. 10) – fix loosely (see the drawing).
3. Fix the bumper to side brackets (pos. 5 and 6) of the towbar – use bolts previously unscrewed from factory handles.
4. Slip the main bar of the towbar (pos. 1) between elements of the towbar (pos. 4) and fix using bolts M12x40mm (pos. 9).
5. Fix body of the automat (pos. 15) and the socket plate (pos. 3) using bolts M12x25mm (pos. 7) from accessories. Place tow-ball (pos. 2) according to supplied instruction.
6. Tighten all bolts according to the torque shown in the table.
7. Connect electric wires of 7-poles socket according to the instruction of the car. (Recommend to make at authorized service station).
8. Complete paint layer damaged during installation.

Torque settings for nuts and bolts (8,8):	
<b>M 8</b> - 25 Nm	<b>M 10</b> - 55 Nm
<b>M 12</b> - 85 Nm	<b>M 14</b> - 135 Nm

## NOTE

After install the towbar you should get adequate note in registration book (at authorised service station).The car should be equipped with:

- Indicators
- Tow mirrors

After 1000km of exploitation check all bolts and nuts. The ball of towbar must be always kept clear and conserve with a grease.