

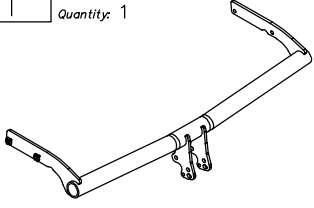

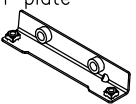







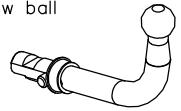

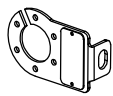
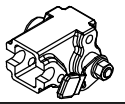
Towbar accessories:

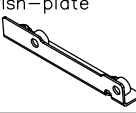
Pos. 1 Name: Main bar Quantity: 1	Pos. 5 Name: Left fish-plate Quantity: 1	Pos. 10 Name: Body plug Quantity: 1
		
Pos. 2 Name: Tow ball Quantity: 1	Pos. 6 Name: Bolt 8,8 B Quantity: 4 Dim.: M12x25mm	Pos. 11 Name: Plain washer Quantity: 4 Dim.: Ø 13 mm
		
Pos. 3 Name: Socket plate Quantity: 1	Pos. 7 Name: Body of the automat Quantity: 1	Pos. 12 Name: Plain washer Quantity: 8 Dim.: Ø 10,5 mm
		
Pos. 4 Name: Right fish-plate Quantity: 1	Pos. 8 Name: Bolt 8,8 B Quantity: 4 Dim.: M10x45mm	Pos. 13 Name: Spring washer Quantity: 4 Dim.: Ø 12,2 mm
		
	Pos. 9 Name: Bolt 8,8 B Quantity: 4 Dim.: M10x25mm	Pos. 14 Name: Spring washer Quantity: 8 Dim.: Ø 10,2 mm
		
		Pos. 15 Name: Ball cover Quantity: 1
		



PPUH AUTO-HAK Sp.J.

Produkcja Zaczepów Kulowych
Henryk & Zbigniew Nejman
76-200 SŁUPSK ul. Słoneczna 16K
tel/fax (059) 8-414-414; 8-414-413
E-mail: office@autohak.com.pl
www.autohak.com.pl

Towing hitch (without electrical set)

Class: **A50-X** Cat. no. **V65A**

Designed for:

Manufacturer: **NISSAN**

Model: **NOTE**

produced since 2006 till 10.2013

Technical data:

D-value: 6,9 kN

maximum trailer weight: **1200 kg**

maximum vertical cup load: **50 kg**

Approval number acc. to regulations EKG/ONZ 55.01: E20-55R-01 4199

Foreword

This towbar is designed according to rules of safety traffic regulations. The towing hitch is a safety component and can be install only by qualified personnel. Any alteration or conversion of the towing hitch is prohibited and would lead to cancellation of design certification. Remove insulating compound and underseal from vehicle (if present) in the area of the matting surfaces of the towing hitch. The vehicle manufacturer's specifications regarding trailer load and max. vertical cup load are decisive for driving whereat values for the towing hitch cannot be exceeded.

D-value formula:

$$\frac{\text{Max trailer weight [kg]} \times \text{Max vehicle weight [kg]}}{\text{Max trailer weight [kg]} + \text{Max vehicle weight [kg]}} \times \frac{9,81}{1000} = D \text{ [kN]}$$

FITTING INSTRUCTION

Clamp mark in acc. with		Cables joining
ISO	PN	
1	L	Left directional lights
2	+	Rear fog lights
3	31	Ground
4	R	Right directional lights
5	58R	Right side parking lights
6	54	Stoplights
7	58L	Left side parking lights

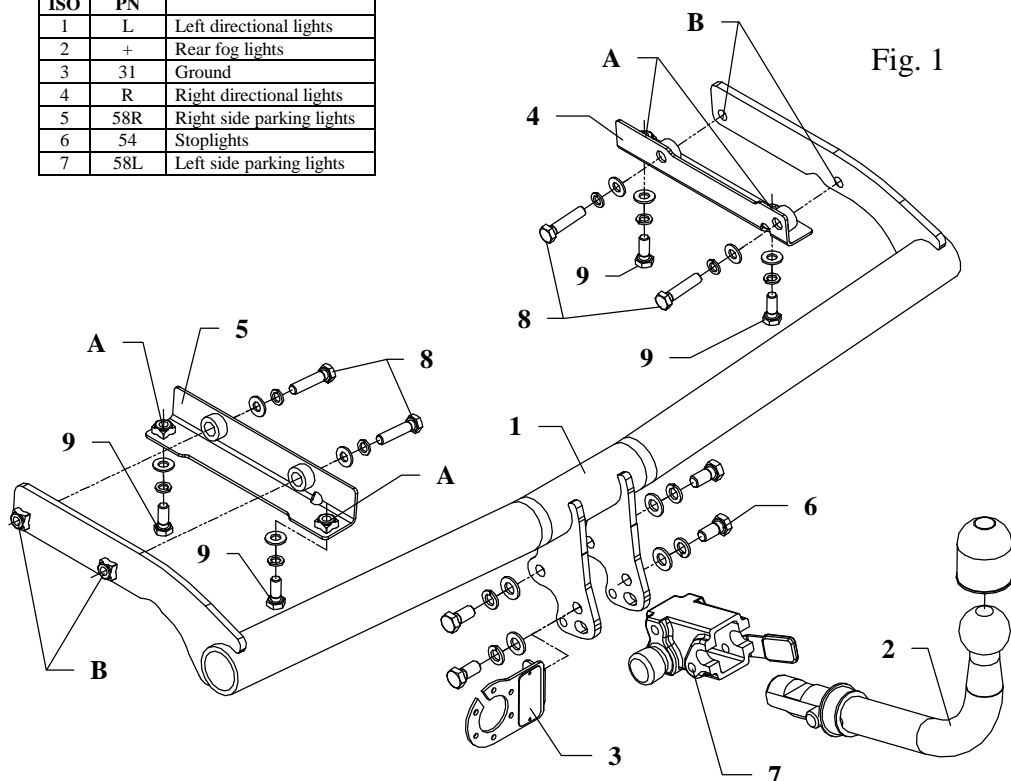

This towbar is designed to assembly in following cars: **NISSAN NOTE**, produced since 2006 till 10.2013, catalogue no. **V65A** and is prepared to tow trailers max total weight **1200 kg** and max vertical load **50 kg**.

From manufacturer

Thank you for buying our product. Their reliability has been confirmed in many tests. Reliability of towbar depends also on correct assembly and right operation. For this reasons we kindly ask to read carefully this instruction and apply to hints.

The towbar should be install in points described by a car producer.

The instruction of the assembly

1. Disassemble a rear bumper.
2. Disassemble supports of bumper on the left and right side (not used any more).
3. Put fish-plates (pos. 4 and 5) in this way so holes in fish-plates agree with original holes prepared by a car producer. Fish-plates fix loosely in points (pos. A) using bolts M10x25mm (pos. 9) from towbar accessories.
4. Put main bar of the towbar (pos. 1) to chassis frame. Fix using bolts M10x45mm (pos. 8) through holes (pos. B) as shown on the figure 1.
5. Cut out fragment bumper's reinforcement according to figure 2.

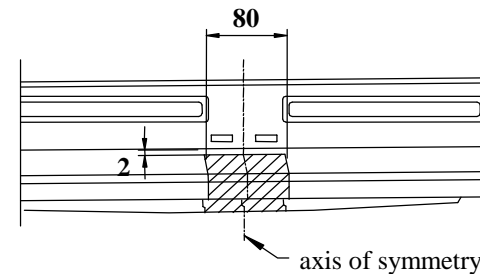

Fig. 2

6. Reassemble a bumper after cut out its fragment (underneath, in axis of symmetry) – width 80mm and depth 70mm.
7. Fix body of the automat (pos. 7) and the socket plate (pos. 3) using bolts M12x25mm (pos. 6) from accessories. Place tow-ball (pos. 2) according to supplied instruction.
8. Tighten all bolts according to the torque shown in the table.
9. Connect electric wires of 7-poles socket according to the instruction of the car. (Recommend to make at authorized service station).
10. Complete paint layer damaged during installation.

Torque settings for nuts and bolts (8,8):	
M 8 - 25 Nm	M 10 - 55 Nm
M 12 - 85 Nm	M 14 - 135 Nm

NOTE

After install the towbar you should get adequate note in registration book (at authorised service station).The car should be equipped with:

- Indicators
- Tow mirrors

After 1000km of exploitation check all bolts and nuts. The ball of towbar must be always kept clear and conserve with a grease.