

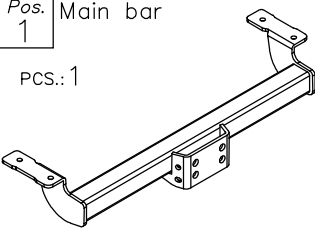

## Towing hitch accessories:

Pos. 1 Main bar PCS.: 1	Pos. 5 Bolt 8,8 B M12x1.25x35mm PCS.: 4	Pos. 10 Plain washer ø13mm PCS.: 4
	Pos. 6 Bolt 8,8 B M10x30mm PCS.: 1	Pos. 11 Plain washer ø10.5mm PCS.: 1
	Pos. 7 Nut 8 B M16 PCS.: 2	Pos. 12 Spring washer ø16.3mm PCS.: 2
Pos. 2 Tow ball PCS.: 1	Pos. 8 Nut 8 B M10 PCS.: 1	Pos. 13 Spring washer ø12.2mm PCS.: 4
Pos. 3 Socket plate PCS.: 1	Pos. 9 Plain washer ø17mm PCS.: 2	Pos. 14 Spring washer ø10.2mm PCS.: 1
Pos. 4 Bolt 8,8 B M16x50mm PCS.: 2	Pos. 15 Ball cover PCS.: 1	



**PPUH AUTO-HAK Sp.J.**

Produkcja Zaczepów Kulowych  
Henryk & Zbigniew Nejman  
76-200 SŁUPSK ul. Słoneczna 16K  
tel/fax (059) 8-414-414; 8-414-413  
E-mail: [office@autohak.com.pl](mailto:office@autohak.com.pl)  
[www.autohak.com.pl](http://www.autohak.com.pl)

## Towing hitch (without electrical set)

Class: **A50-X** Cat. no. **W05**

Designed for:

Manufacturer: **SUZUKI**

Model: **VITARA**

Type: **5 doors, except V6**

produced since 03.1995 till 08.1998

Technical data:

**D-value: 9,2 kN**

maximum trailer weight: **1875 kg**

maximum vertical cup load: **75 kg**

**Approval number according to Directive 94/20/EC: e20\*94/20\*0478\*00**

## Foreword

This towing hitch is designed according to rules of safety traffic regulations. The towing hitch is a safety component and can be install only by qualified personnel. Any alteration or conversion of the towing hitch is prohibited and would lead to cancellation of design certification. Remove insulating compound and underseal from vehicle (if present) in the area of the matting surfaces of the towing hitch. The vehicle manufacturer's specifications regarding trailer load and max. vertical cup load are decisive for driving whereat values for the towing hitch cannot be exceeded.

*D-value formula:*

$$\frac{\text{Max trailer weight [kg]} \times \text{Max vehicle weight [kg]}}{\text{Max trailer weight [kg]} + \text{Max vehicle weight [kg]}} \times \frac{9,81}{1000} = D \text{ [kN]}$$

## FITTING INSTRUCTION

Clamp mark in acc. with		Cables joining
ISO	PN	
1	L	Left directional lights
2	+	Rear fog lights
3	31	Ground
4	R	Right directional lights
5	58R	Right side parking lights
6	54	Stoplights
7	58L	Left side parking lights

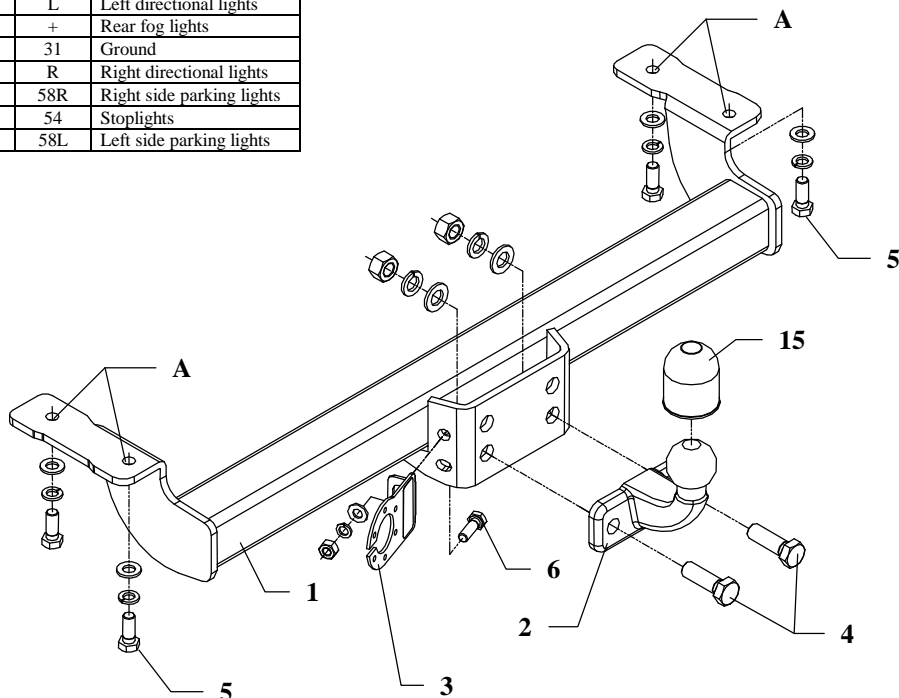

This towing hitch is designed to assembly in following cars:  
**SUZUKI VITARA, 5 doors, except V6**, produced since 03.1995 till 08.1998, catalogue no. **W05** and is prepared to tow trailers max total weight **1875 kg** and max vertical load **75 kg**.

### *From manufacturer*

Thank you for buying our product. Their reliability has been confirmed in many tests. Reliability of towing hitch depends also on correct assembly and right operation. For this reasons we kindly ask to read carefully this instruction and apply to hints.

*The towing hitch should be install in points described by a car producer.*

## The instruction of the assembly

1. Disassemble original towing eye (it will not be used anymore).
2. Put the main bar of the towing hitch (pos. 1) underneath the car to chassis frame and through holes A and original threaded holes in the frame fix using bolts M12x1.25x35mm (pos. 5) from towing hitch accessories.
3. To installed bar of the towing hitch fix the tow-ball (pos. 2) using bolts M16x50mm (pos. 4) from accessories.
4. Fix the socket plate (pos. 3) using bolt M10x30mm (pos. 6).
5. Tighten all bolts according to the torque shown in the table.
6. Connect electric wires of 7-poles socket according to the instruction of the car. (Recommend to make at authorized service station).
7. Complete paint layer damaged during installation.

Torque settings for nuts and bolts (8,8):

<b>M6</b> - 11 Nm	<b>M8</b> - 25 Nm	<b>M10</b> - 50 Nm
<b>M12</b> - 87 Nm	<b>M14</b> - 138 Nm	<b>M16</b> - 210 Nm

## NOTE

After install the towing hitch you should get adequate note in registration book (at authorised service station).The car should be equipped with:

- Indicators
- Tow mirrors

After 1000km check all bolts. The ball of towing hitch must be always kept clear and conserve with a grease.