

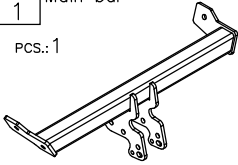











## Towing hitch accessories:

Pos. 1 Main bar PCS.: 1	Pos. 5 Right bracket PCS.: 1	Pos. 10 Bolt 8.8 B M12x35mm PCS.: 4	Pos. 15 Nut 8 B M10 PCS.: 9
	Pos. 6 Plate PCS.: 2	Pos. 11 Bolt 8.8 B M10x100mm PCS.: 1	Pos. 16 Washer ø13mm PCS.: 4
	Pos. 7 Fish-plate PCS.: 2	Pos. 12 Bolt 8.8 B M10x40mm PCS.: 4	Pos. 17 Washer ø10,5mm PCS.: 9
	Pos. 8 Washer ø58xø13x6mm PCS.: 2	Pos. 13 Bolt 8.8 B M10x30mm PCS.: 4	Pos. 18 Spring washer ø12,2mm PCS.: 4
Pos. 2 Tow ball PCS.: 1	Pos. 9 Distance sleeve ø25xø15mm L=18mm PCS.: 2	Pos. 14 Nut 8 B M12 PCS.: 2	Pos. 19 Spring washer ø10,2mm PCS.: 9
			
Pos. 3 Socket plate PCS.: 1			
Pos. 4 Left bracket PCS.: 1			



**PPUH AUTO-HAK Sp.J.**

Produkcja Zaczepów Kulowych  
Henryk & Zbigniew Nejman  
76-200 SŁUPSK ul. Słoneczna 16K  
tel/fax (059) 8-414-414; 8-414-413  
E-mail: [office@autohak.com.pl](mailto:office@autohak.com.pl)  
[www.autohak.com.pl](http://www.autohak.com.pl)

## Towing hitch (without electrical set)

Class: **A50-X** Cat. no. **W13A**

Designed for:

Manufacturer: **SUZUKI**

Model: **SWIFT**

Type: **3/5 doors, except 4WD**

produced since 03.1989 till 09.1996 and  
since 10.1996 till 10.2003

Technical data:

**D-value: 5,45 kN**

maximum trailer weight: **1000 kg**

maximum vertical cup load: **50 kg**

Approval number according to Directive 94/20/EC: **e20\*94/20\*1144\*00**

## Foreword

This towing hitch is designed according to rules of safety traffic regulations. The towing hitch is a safety component and can be installed only by qualified personnel. Any alteration or conversion of the towing hitch is prohibited and would lead to cancellation of design certification. Remove insulating compound and underseal from vehicle (if present) in the area of the mating surfaces of the towing hitch. The vehicle manufacturer's specifications regarding trailer mass and max. vertical cup mass are decisive for driving whereat values for the towing hitch cannot be exceeded.

*D-value formula:*

$$\frac{\text{Max trailer weight [kg]} \times \text{Max vehicle weight [kg]}}{\text{Max trailer weight [kg]} + \text{Max vehicle weight [kg]}} \times \frac{9,81}{1000} = D \text{ [kN]}$$

## FITTING INSTRUCTION

Clamp mark in acc. with		Cables joining
ISO	PN	
1	L	Left directional lights
2	+	Rear fog lights
3	31	Ground
4	R	Right directional lights
5	58R	Right side parking lights
6	54	Stoplights
7	58L	Left side parking lights

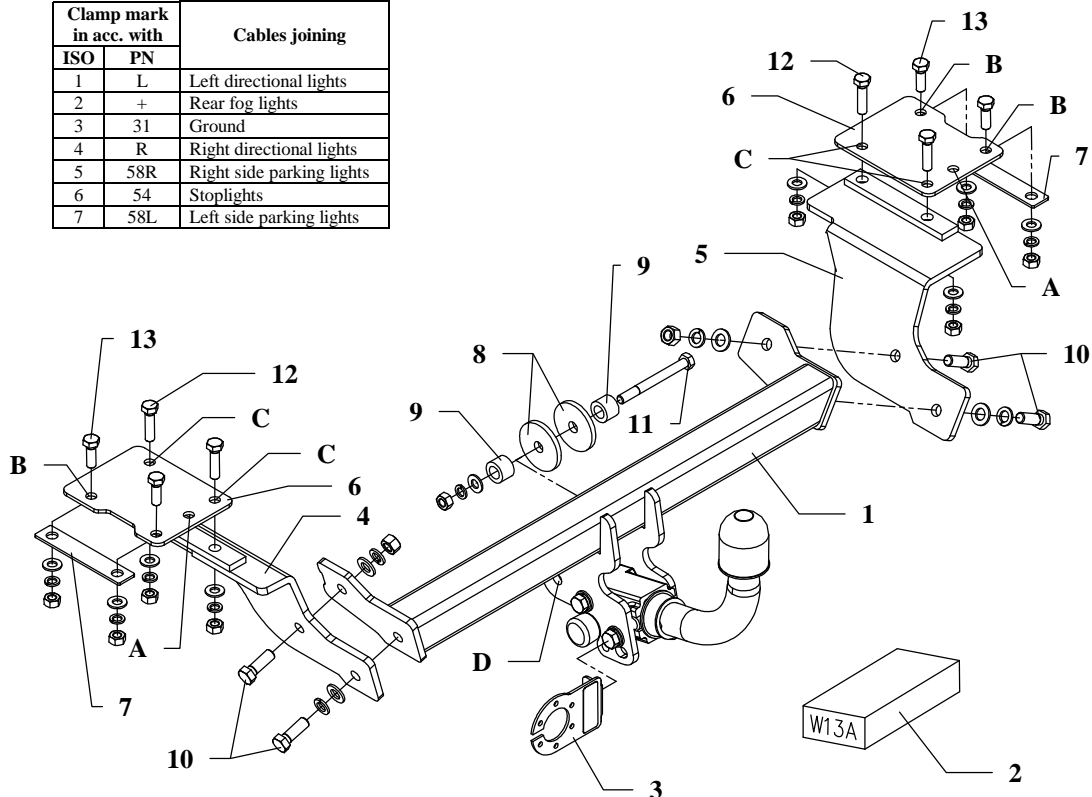

This towing hitch is designed to assembly in following cars: **SUZUKI SWIFT, 3/5 doors, except 4WD**, produced since 03.1989 till 09.1996 and since 10.1996 till 10.2003, catalogue no. **W13A** and is prepared to tow trailers max total weight **1000 kg** and max vertical load **50 kg**.

### From manufacturer

Thank you for buying our product. Their reliability has been confirmed in many tests. Reliability of towing hitch depends also on correct assembly and right operation. For this reasons we kindly ask to read carefully this instruction and apply to hints.

*The towing hitch should be install in points described by a car producer.*

## The instruction of the assembly

1. Disassemble the bumper.
2. Take out the noise mat from the boot.

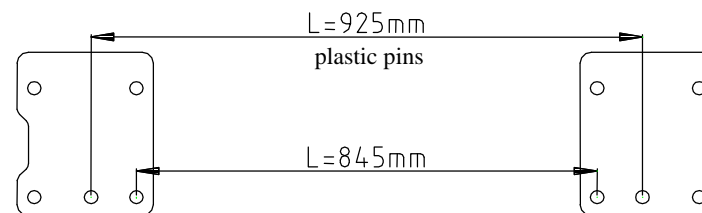

Fig.2 Elements distance

3. On the left and right side in the boot are plastic pins (diameter 11mm). On this pins put elements pos. 6 (check position of hole A) – see fig. 2. Next drill holes through holes pos. B and C, use bit Ø11 mm, drill straight through.
4. Put bolts M10x40 through holes (pos. C) in element pos. 6 and next from below of car put element (pos. 4) from the left side (fix loosely), from the right side put element (pos. 5) - fix loosely too.  
- to easier install get lower the muffler (take off from rubber handles)
5. Through holes pos. B (in elements pos. 6) put bolts M10x30 and fix them with floor and element (pos. 7).
6. In this way prepared elements (pos. 4 and 5) put main bar of the towbar (pos. 1) and fix it using bolts M12x30 (loosely).
7. Through holes (pos. D) fix with original tow handle using distance plain washers Ø58xØ12x6 (pos. 8).
8. Fix all bolts according to the torque shown in the table.
9. Reassemble the bumper after cut out required fragment in bottom edge.
10. Fix body of the automat and place tow-ball according to supplied instruction. Note! Remember to place socket plate (pos. 3) as shown on the drawing 1.
11. Connect electric wires according to the instruction of the car. (Recommend to make at authorized service station)
12. Complete the paint coating damaged during installation.

### Torque settings for nuts and bolts (8,8):

<b>M6</b> - 11 Nm	<b>M8</b> - 25 Nm	<b>M10</b> - 50 Nm
<b>M12</b> - 87 Nm	<b>M14</b> - 138 Nm	<b>M16</b> - 210 Nm

### NOTE

After install the towbar you should get adequate note in registration book (at authorised service station).The car should be equipped with:

- Indicators
- Tow mirrors

After 1000km of exploitation check all bolts and nuts. The ball of towbar must be always kept clear and conserve with a grease.