

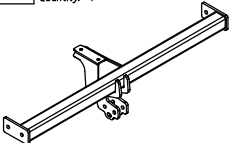









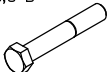



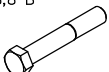

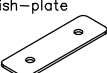
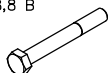

## Towbar accessories:

Pos. 1 Name: Main bar Quantity: 1	Pos. 5 Name: Left bracket Quantity: 1	Pos. 10 Name: Bolt 8,8 B Quantity: 1 Dim.: M12x75mm	Pos. 15 Name: Nut 8 B Quantity: 4 Dim.: M10
			
Pos. 2 Name: Tow ball Quantity: 1	Pos. 6 Name: Distance sleeve I Quantity: 2 Dim.: Ø26,9x2,9 L=52mm	Pos. 11 Name: Bolt 8,8 B Quantity: 1 Dim.: M12x70mm	Pos. 16 Name: Plain washer Quantity: 6 Dim.: Ø 13 mm
			
Pos. 3 Name: Socket plate Quantity: 1	Pos. 7 Name: Distance sleeve II Quantity: 2 Dim.: Ø17,2x2,35 L=52mm	Pos. 12 Name: Bolt 8,8 B Quantity: 4 Dim.: M12x35mm	Pos. 17 Name: Plain washer Quantity: 4 Dim.: Ø 10,5 mm
			
Pos. 4 Name: Right bracket Quantity: 1	Pos. 8 Name: Right fish-plate Quantity: 1	Pos. 13 Name: Bolt 8,8 B Quantity: 4 Dim.: M10x80mm	Pos. 18 Name: Spring washer Quantity: 6 Dim.: Ø 12,2 mm
			
Pos. 9 Name: Left fish-plate Quantity: 1	Pos. 14 Name: Nut 8 B Quantity: 4 Dim.: M12	Pos. 19 Name: Spring washer Quantity: 4 Dim.: Ø 10,2 mm	Pos. 20 Name: Ball cover Quantity: 1
			

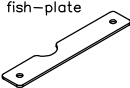

**PPUH AUTO-HAK S.J.**

Produkcja Zaczepów Kulowych  
Henryk & Zbigniew Nejman  
76-200 SŁUPSK ul. Słoneczna 16K  
tel/fax (059) 8-414-414; 8-414-413  
email: [office@autohak.com.pl](mailto:office@autohak.com.pl)  
[www.autohak.com.pl](http://www.autohak.com.pl)

## Towing hitch (without electrical set)

Class: **A50-X** Cat. no. **W14**

Designed for:

**OPEL AGILA, 5D**

**SUZUKI WAGON R+, 5D**

produced since 04.2000 till 09.2002

Technical data:

**D-value: 5,65 kN**

maximum trailer weight: **1000 kg**

maximum vertical cup load: **30 kg**

**Approval number according to Directive 94/20/EC: e20\*94/20\*0886\*00**

## Foreword

This towbar is designed according to rules of safety traffic regulations. The towing hitch is a safety component and can be installed only by qualified personnel. Any alteration or conversion of the towing hitch is prohibited and would lead to cancellation of design certification. Remove insulating compound and underseal from vehicle (if present) in the area of the matting surfaces of the towing hitch. The vehicle manufacturer's specifications regarding trailer load and max. vertical cup load are decisive for driving, and values for the towing hitch cannot be exceeded.

*D-value formula:*

$$\frac{\text{Max trailer weight [kg]} \times \text{Max vehicle weight [kg]}}{\text{Max trailer weight [kg]} + \text{Max vehicle weight [kg]}} \times \frac{9,81}{1000} = D \text{ [kN]}$$

## FITTING INSTRUCTION

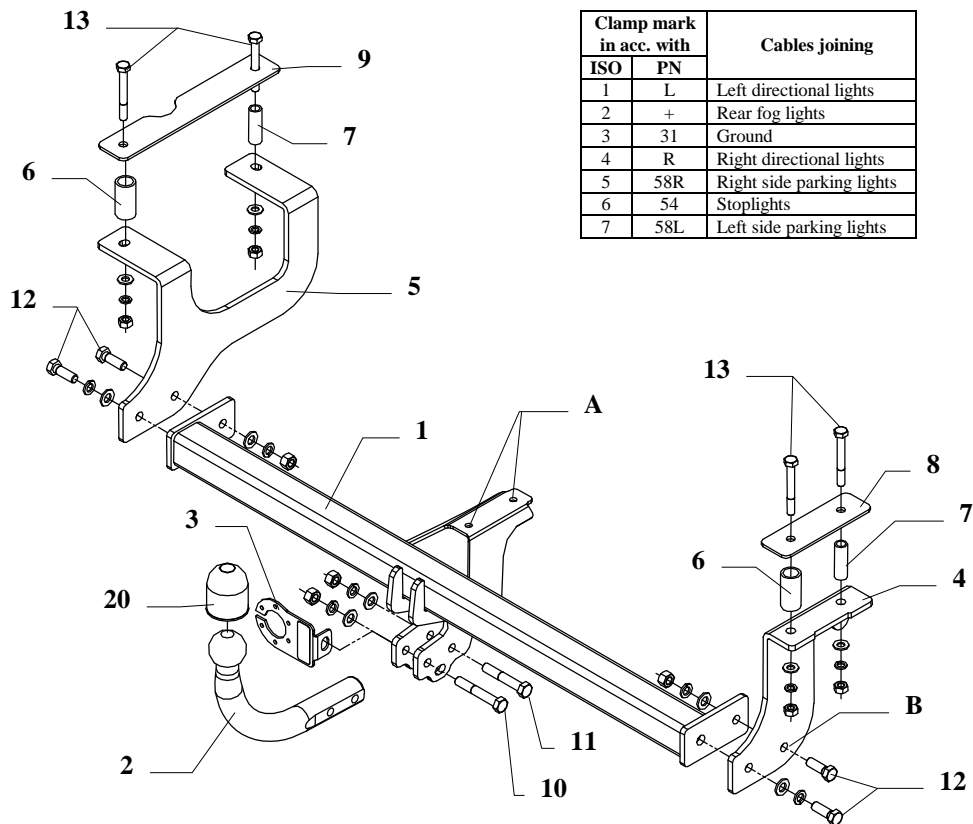

Clamp mark in acc. with		Cables joining
ISO	PN	
1	L	Left directional lights
2	+	Rear fog lights
3	31	Ground
4	R	Right directional lights
5	58R	Right side parking lights
6	54	Stoplights
7	58L	Left side parking lights

This towbar is designed to assembly in following cars:  
**SUZUKI WAGON R+, 5D** and **OPEL AGILA, 5D** produced since 04.2000 till 09.2002, catalogue no. **W14** and is prepared to tow trailers max total weight **1000 kg** and max vertical load **30 kg**.

### From manufacturer

Thank you for buying our product. Their reliability has been confirmed in many tests. Reliability of towbar depends also on correct assembly and right operation. For this reasons we kindly ask to read carefully this instruction and apply to hints.

*The towbar should be install in points described by a car producer.*

## The instruction of the assembly

- To install this towbar You have to:
  - take out the carpet from the trunk,
  - disassemble plastic covers from side and rear panel,
  - disassemble original tow eye, (not used any more)
  - from the left chassis member twist off handle of the fuel line,
  - take out from both members per one plastic plug (from below),
  - inside boot, take out plastic plug, one per each side.
- Cut out enclosed templates and next put them according to dimension L=1076mm (inside the trunk). Holes must agree!. Mark points to drill.
- Drill according to the figure.
- To drilled holes put suitable distance sleeves pos. 6 and pos. 7.
- Put fish-plate (pos. 9) on the left side and fish-plate (pos. 8) on the right side and next put bolts M10x80mm (pos. 13).
- From below the car, on the left side put (under fuel lines) left bracket (pos. 5) and screw loosely . On the right side put right bracket (pos. 4) and screw loosely.
- Between brackets pos. 4 and 5 slip main bar of the towbar (pos. 1) and twist on:
  - through holes pos. A to original holes of tow eye (use original bolts M8),
  - through holes pos. B in side brackets by bolts M12x35mm (pos. 12) from accessories, see figure.
- Fix tow-ball (pos. 2) and socket plate (pos. 3) by bolts M12x75mm (pos. 10) and M12x70mm (pos. 11) from accessories.
- Tighten all bolts according to the torque shown in the table.
- Connect electric wires of 7-poles socket according to the instruction of the car. (Recommend to make at authorized service station)
- Complete paint layer damaged during installation.

Torque settings for nuts and bolts (8,8):

<b>M6</b> - 11 Nm	<b>M8</b> - 25 Nm	<b>M10</b> - 50 Nm
<b>M12</b> - 87 Nm	<b>M14</b> - 138 Nm	<b>M16</b> - 210 Nm

### NOTE

After install the towbar you should get adequate note in registration book (at authorised service station).The car should be equipped with:

- Indicators
- Tow mirrors

After 1000km of exploitation check all bolts and nuts. The ball of towbar must be always kept clear and conserve with a grease.