

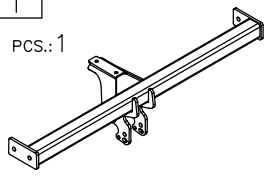











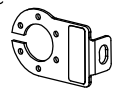
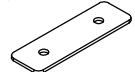

Towing hitch accessories:

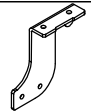
Pos. 1 Main bar PCS.: 1	Pos. 6 Distance sleeve Ø26,9x2,9mm L=52mm PCS.: 2	Pos. 12 Nut 8 B M12 PCS.: 2
		
Pos. 2 Tow ball PCS.: 1	Pos. 7 Distance sleeve Ø17,2x2,35mm L=52mm PCS.: 2	Pos. 13 Nut 8 B M10 PCS.: 4
		
Pos. 3 Socket plate PCS.: 1	Pos. 8 Right fish-plate PCS.: 1	Pos. 14 Plain washer Ø13mm PCS.: 4
		
Pos. 4 Right bracket PCS.: 1	Pos. 9 Left fish-plate PCS.: 1	Pos. 15 Plain washer Ø10,5mm PCS.: 4
		
Pos. 5 Left bracket PCS.: 1	Pos. 10 Bolt 8.8 B M12x35mm PCS.: 4	Pos. 16 Spring washer Ø12,2mm PCS.: 4
		
	Pos. 11 Bolt 8.8 B M10x80mm PCS.: 4	Pos. 17 Spring washer Ø10,2mm PCS.: 4
		

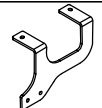

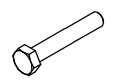
PPUH AUTO-HAK S.J.

Produkcja Zaczepów Kulowych
Henryk & Zbigniew Nejman
76-200 SŁUPSK ul. Słoneczna 16K
tel/fax (059) 8-414-414; 8-414-413
email: office@autohak.com.pl
www.autohak.com.pl

Towing hitch (without electrical set)

Class: **A50-X** Cat. no. **W14A**

Designed for:

OPEL AGILA, 5D

SUZUKI WAGON R+, 5D

produced since 04.2000 till 09.2002

Technical data:

D-value: 5,65 kN

maximum trailer weight: **1000 kg**

maximum vertical cup load: **30 kg**

Approval number according to Directive 94/20/EC: e20*94/20*0867*00

Foreword

This towbar is designed according to rules of safety traffic regulations. The towing hitch is a safety component and can be install only by qualified personnel. Any alteration or conversion of the towing hitch is prohibited and would lead to cancellation of design certification. Remove insulating compound and underseal from vehicle (if present) in the area of the matting surfaces of the towing hitch.

The vehicle manufacturer's specifications regarding trailer load and max. vertical cup load are decisive for driving whereat values for the towing hitch cannot be exceeded.

D-value formula:

$$\frac{\text{Max trailer weight [kg]} \times \text{Max vehicle weight [kg]}}{\text{Max trailer weight [kg]} + \text{Max vehicle weight [kg]}} \times \frac{9,81}{1000} = D \text{ [kN]}$$

FITTING INSTRUCTION

Clamp mark in acc. with		Cables joining
ISO	PN	
1	L	Left directional lights
2	+	Rear fog lights
3	31	Ground
4	R	Right directional lights
5	58R	Right side parking lights
6	54	Stoplights
7	58L	Left side parking lights

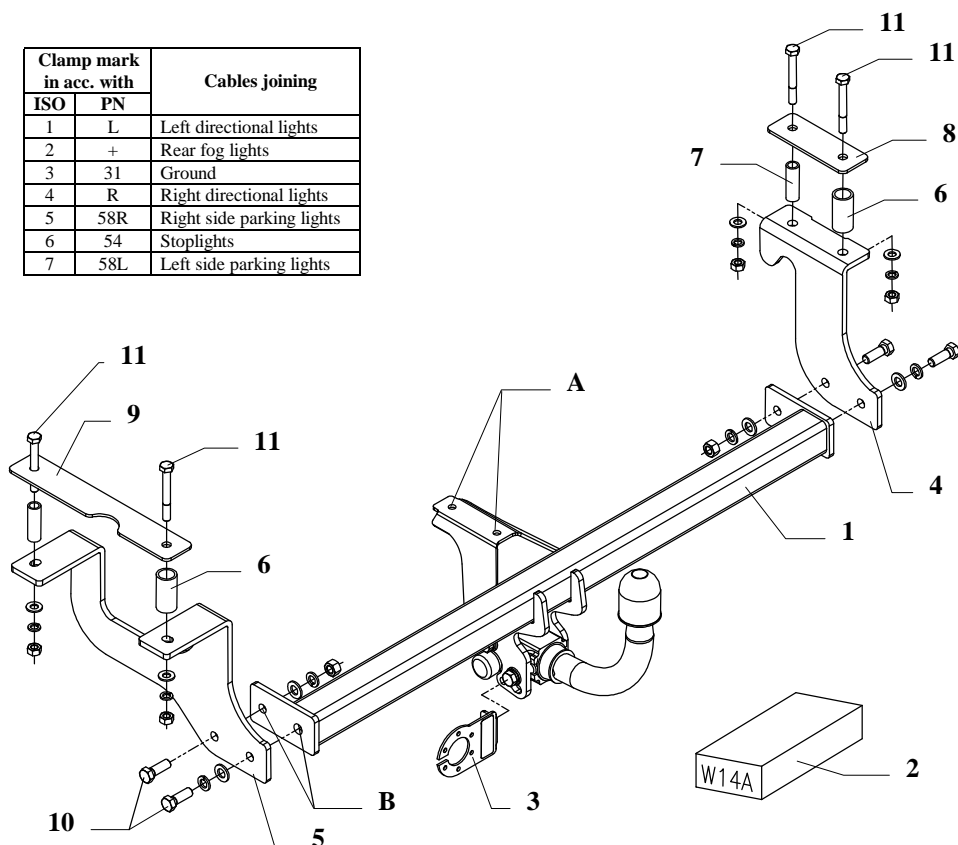

This towbar is designed to assembly in following cars: **SUZUKI WAGON R+, 5D** and **OPEL AGILA, 5D** produced since 04.2000 till 09.2002, catalogue no. **W14A** and is prepared to tow trailers max total weight **1000 kg** and max vertical load **30 kg**.

From manufacturer

Thank you for buying our product. Their reliability has been confirmed in many tests. Reliability of towbar depends also on correct assembly and right operation. For this reasons we kindly ask to read carefully this instruction and apply to hints.

The towbar should be install in points described by a car producer.

The instruction of the assembly

- To install this towing hitch:
 - take out the carpet from the trunk,
 - disassemble plastic covers from side and rear panel,
 - disassemble original tow eye (will not use any more)
 - from the left chassis member twist off handle of the fuel line,
 - take out from both members per one plastic plug (from below),
 - inside boot, take out plastic plug, one per each side.
- Cut out enclosed templates and next put them according to dimension L=1076mm (inside the trunk). Holes must agree! Mark points to drill.
- Drill according to the figure.
- To drilled holes put suitable distance sleeves (pos. 6 and 7).
- Put fish-plate (pos. 9) on the left side and fish-plate (pos. 8) on the right side and next put bolts M10x80mm (pos. 11).
- From below the car, on the left side put (under fuel lines) left bracket (pos. 5) and fix loosely. On the right side put right bracket (pos. 4) and fix loosely.
- Between brackets (pos. 4 and 5) slip main bar of the towing hitch (pos. 1) and twist on:
 - through holes pos. A to original holes of tow eye (use original bolts M8),
 - through holes pos. B in side brackets by bolts M12x35mm (pos. 10) from accessories, see figure.
- Fix body of the automat and place tow-ball according to supplied instruction. Note! Remember to place socket plate (pos. 3) as shown on the drawing 1.
- Tighten all bolts according to the torque shown in the table.
- Connect electric wires of 7-poles socket according to the instruction of the car. (Recommend to make at authorized service station)
- Complete paint layer damaged during installation.

Torque settings for nuts and bolts (8,8):

M 8	25 Nm	M 10	55 Nm
M 12	85 Nm	M 14	135 Nm

NOTE

After install the towbar you should get adequate note in registration book (at authorised service station).The car should be equipped with:

- Indicators
- Tow mirrors

After 1000km of exploitation check all bolts and nuts. The ball of towbar must be always kept clear and conserve with a grease.