

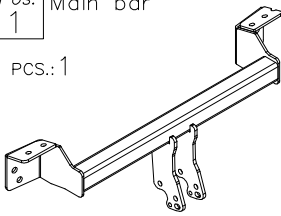

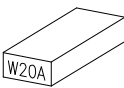

## Towbar accessories:

Pos. 1 Main bar PCS.: 1	Pos. 6 Distance fish-plate PCS.: 2	Pos. 12 Plain washer Ø13mm PCS.: 14
	Pos. 7 Right fish-plate PCS.: 1	Pos. 13 Spring washer Ø12,2mm PCS.: 14
Pos. 2 Tow ball PCS.: 1	Pos. 8 Left fish-plate PCS.: 1	Pos. 14 Nut 8 B M12 PCS.: 14
	Pos. 9 Ball cover PCS.: 1	
Pos. 3 Socket plate PCS.: 1		
Pos. 4 Right handle PCS.: 1	Pos. 10 Bolt 8,8 B M12x45mm PCS.: 4	
Pos. 5 Left handle PCS.: 1	Pos. 11 Bolt 8,8 B M12x35mm PCS.: 10	

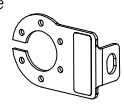

## PPUH AUTO-HAK Sp.J.

Produkcja Zaczepów Kulowych  
Henryk & Zbigniew Nejman  
76-200 SŁUPSK ul. Słoneczna 16K  
tel/fax (059) 8-414-414; 8-414-413  
E-mail: [office@autohak.com.pl](mailto:office@autohak.com.pl)  
[www.autohak.com.pl](http://www.autohak.com.pl)

### Towing hitch (without electrical set)

Class: **A50-X** Cat. no. **W20A**

Designed for:

Manufacturer: **SUZUKI**

Model: **LIANA**

Type: **4 doors**

produced since 03.2002 till 12.2007

Technical data:

**D-value: 6,9 kN**

maximum trailer weight: **1200 kg**

maximum vertical cup load: **75 kg**

Approval number according to Directive 94/20/EC: **e20\*94/20\*1192\*00**

### Foreword

This towbar is designed according to rules of safety traffic regulations. The towing hitch is a safety component and must be installed only by qualified personnel. Any alteration or conversion to the towing hitch is prohibited and would lead to cancellation of design certification. Remove insulating compound and underseal from vehicle (if present) in the area of the matting surfaces of the towing hitch.

The vehicle manufacturer's specifications regarding trailer load and max. vertical cup load are decisive for driving, and values for the towing hitch must not be exceeded.

*D-value formula:*

$$\frac{\text{Max trailer weight [kg]} \times \text{Max vehicle weight [kg]}}{\text{Max trailer weight [kg]} + \text{Max vehicle weight [kg]}} \times \frac{9,81}{1000} = D \text{ [kN]}$$

## FITTING INSTRUCTION

Clamp mark in acc. with		Cables joining
ISO	PN	
1	L	Left directional lights
2	+	Rear fog lights
3	31	Ground
4	R	Right directional lights
5	58R	Right side parking lights
6	54	Stoplights
7	58L	Left side parking lights

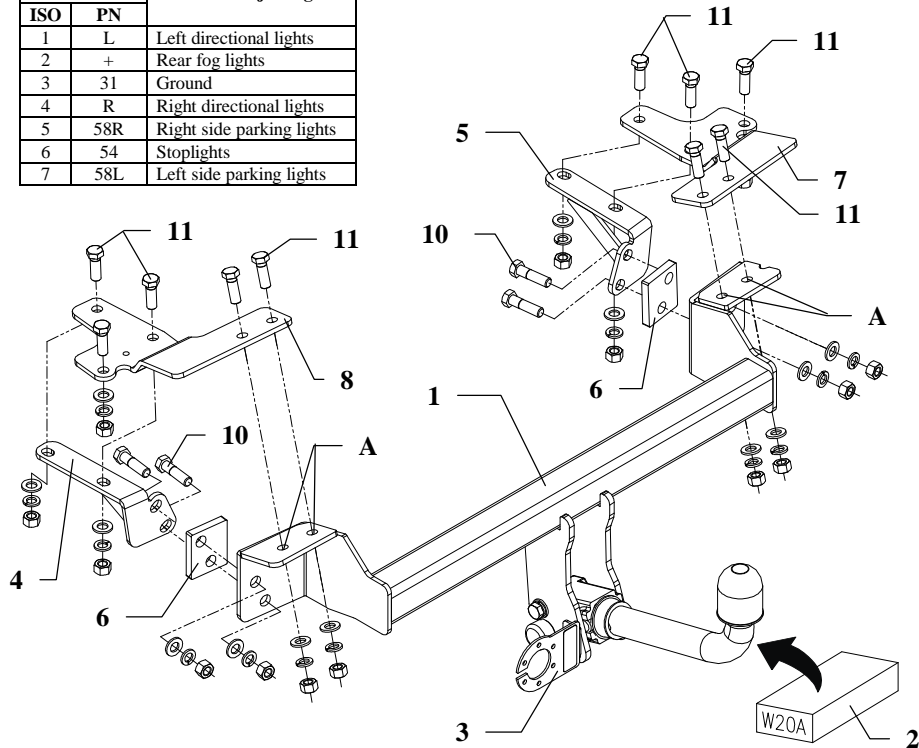

This towbar is designed to assembly in following car: **SUZUKI LIANA, 4 doors**, produced since 03.2002 till 12.2007, cat. no. **W20A** and is prepared to tow trailers max total weight **1200 kg** and max vertical load **75kg**.

### *From manufacturer*

Thank you for buying our product. Their reliability has been confirmed in many tests. Reliability of towbar depends also on correct assembly and right operation. For this reasons we kindly ask to read carefully this instruction and apply to hints.

*The towbar should be install in points described by a car producer.*

## The instruction of the assembly

1. Disassemble rear light and bumper, remove fulfillment of the bumper.
2. Disassemble side, rear panels from boot.
3. Install main bar of the towbar (pos. 1) to rear panel of the car through original holes together with handles pos. 4 and 5 and distance plates pos. 6 using bolts M12x45mm (pos. 10).
4. Through holes pos. A drill holes in rear panel using bit  $\varnothing 13\text{mm}$ . From inside put fish-plates pos. 7 and 8 – see drawing.
5. From inside of boot drill lack holes with bit  $\varnothing 13\text{mm}$ . Twist on by bolts as shown on the drawing.
6. Fix body of the automat and place tow-ball according to supplied instruction. Note! Remember to place socket plate (pos. 3) as shown on the drawing 1.
7. Tighten all bolts according to the torque shown in the table.
8. For models 2002-2004 with spoilers on bumpers : cut in central part of the bumper fragment: width 80 mm and depth 150 mm.
9. For models since year 2004 (from chassis serial number JSAERA31S00200001): cut suitable fragment of the bumper using supplied template and expand it if necessary.
10. Reassemble all dismantled elements.
11. Connect electric wires of 7-pole socket according to the instruction of the car. (Recommend to make at authorized service station)
12. Complete paint layer damaged during installation.

### Torque settings for nuts and bolts (8,8):

<b>M6</b> - 11 Nm	<b>M8</b> - 25 Nm	<b>M10</b> - 50 Nm
<b>M12</b> - 87 Nm	<b>M14</b> - 138 Nm	<b>M16</b> - 210 Nm

### NOTE

After install the towbar you should get adequate note in registration book (at authorised service station).The car should be equipped with:

- Indicators
- Tow mirrors

After 1000km of exploitation check all bolts and nuts. The ball of towbar must be always kept clear and conserve with a grease.