

FITTING INSTRUCTION

Clamp mark in acc. with		Cables joining
ISO	PN	
1	L	Left directional lights
2	+	Rear fog lights
3	31	Ground
4	R	Right directional lights
5	58R	Right side parking lights
6	54	Stoplights
7	58L	Left side parking lights

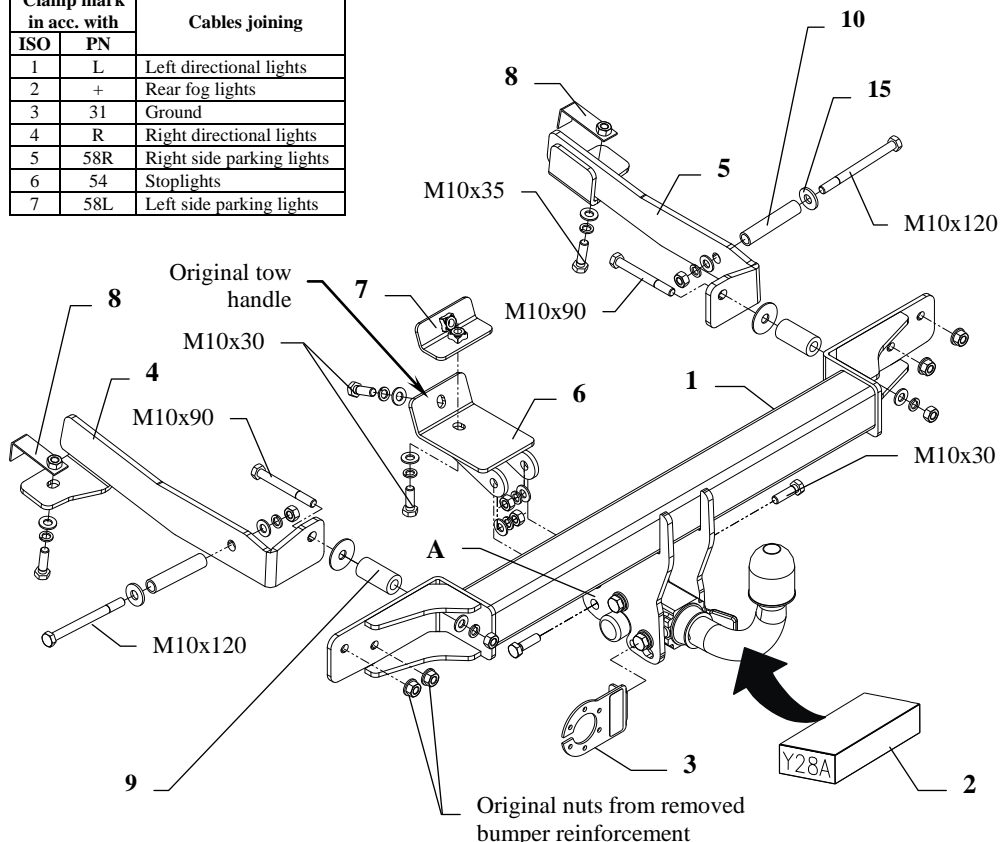

This towing hitch is designed to assembly in following cars: **HONDA ACCORD TOURER Estate (CM1, CM2, CN2), except Type S**, produced since 05.2003 till 07.2008, catalogue no. **Y28A** and is prepared to tow trailers max total weight **1500 kg** and max vertical load **75 kg**.

From manufacturer

Thank you for buying our product. Their reliability has been confirmed in many tests. Reliability of towing hitch depends also on correct assembly and right operation. For this reasons we kindly ask to read carefully this instruction and apply to hints.

The towing hitch should be install in points described by a car producer.

The instruction of the assembly

1. Disassemble the bumper and metal reinforcement (not used any more).
2. In the figure no. 1 and 2 shown points to drill holes $\varnothing 11$ mm.
3. To the left and right chassis member slip sleeve $L=85$ mm (pos. 10), see fig.
4. To drilled holes put sleeves $L=51,5$ mm (pos. 9).
5. To the inside of chassis members and rear part of the car put brackets (pos. 4 and 5) and fix using bolts $M10 \times 120$ mm (pos. 11) through sleeves and bolts $M10 \times 35$ mm (pos. 13) through nuts on the jib (pos. 8).
6. Put the main bar of the towing hitch (pos. 1) on protruding elements (bolts) of removed metal reinforcement and fix using original nuts $M8$ (from reinforcement) and using $M10 \times 90$ mm (pos. 12) - see fig.
7. Elements of the towing hitch (pos. 6 and 7) fix loosely to the original tow handle, and next through holes (pos. A) of ball brackets fix using bolts $M10 \times 30$ mm (pos. 14).
8. Fix body of the automat and place tow-ball according to supplied instruction. Note! Remember to place socket plate (pos. 3) as shown on the drawing 1.
9. Assemble a cover plate and a bumper (cut out its fragment – see fig. 3 and 4).
10. Tighten all bolts according to the torque shown in the table.
11. Connect electric wires of 7-poles socket according to the instruction of the car. (Recommend to make at authorized service station).
12. Supplement the paint coating damaged during assembly.

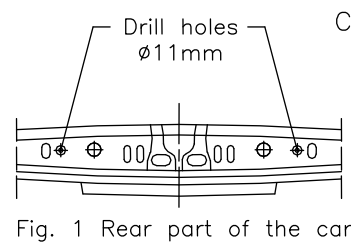

Fig. 1 Rear part of the car

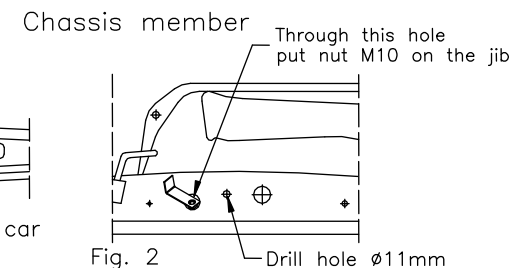

Fig. 2 Drill hole $\varnothing 11$ mm

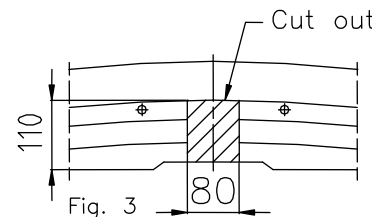

Fig. 3

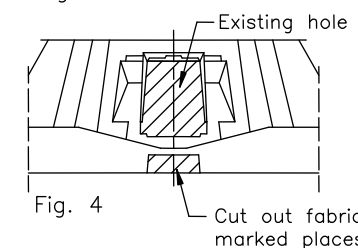

Fig. 4

Torque settings for nuts and bolts (8,8):
M 8 - 25 Nm M 10 - 55 Nm M 12 - 85 Nm M 14 - 135 Nm











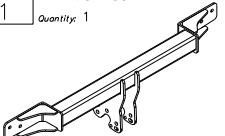
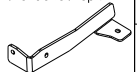



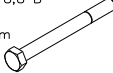

NOTE

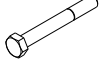
After install the towing hitch you should get adequate note in registration book (at authorised service station).The car should be equipped with:

- Indicators
- Tow mirrors

After 1000km of exploitation check all bolts and nuts. The ball of towing hitch must be always kept clear and conserve with a grease.

Towing hitch accessories:

Pos. 1	Name: Main bar Quantity: 1	Pos. 5	Name: Right bracket cpl. Quantity: 1	Pos. 10	Name: Distance sleeve Quantity: 2 Dim.: $\emptyset 17,2 \times 2,35 \text{ mm}$ L=85mm	Pos. 15	Name: Washer Quantity: 4 Dim.: $\emptyset 30 \times \emptyset 10.5 \times 2.5 \text{ mm}$
							
		Pos. 6	Name: Middle bracket cpl. Quantity: 1	Pos. 11	Name: Bolt 8,8 B Quantity: 2 Dim.: M10x120mm	Pos. 16	Name: Nut 8 B Quantity: 6 Dim.: M10
							
Pos. 2	Name: Tow ball Quantity: 1	Pos. 7	Name: Fish-plate Quantity: 1	Pos. 12	Name: Bolt 8,8 B Quantity: 2 Dim.: M10x90mm	Pos. 17	Name: Plain washer Quantity: 10 Dim.: $\emptyset 10,5 \text{ mm}$
							
Pos. 3	Name: Socket plate Quantity: 1	Pos. 8	Name: Jib with the nut Quantity: 2	Pos. 13	Name: Bolt 8,8 B Quantity: 2 Dim.: M10x35mm	Pos. 18	Name: Spring washer Quantity: 10 Dim.: $\emptyset 10,2 \text{ mm}$
							
Pos. 4	Name: Left bracket cpl. Quantity: 1	Pos. 9	Name: Distance sleeve Quantity: 2 Dim.: $\emptyset 25 \times \emptyset 13 \text{ mm}$ L=51,5mm	Pos. 14	Name: Bolt 8,8 B Quantity: 4 Dim.: M10x30mm		
							



PPUH AUTO-HAK S.J.

Produkcja Zaczepów Kulowych
Henryk i Zbigniew Nejman
76-200 SŁUPSK ul. Słoneczna 16K
tel/fax (059) 8-414-414; 8-414-413
E-mail: office@autohak.com.pl
www.autohak.com.pl

Towing hitch (without electrical set)

Class: **A50-X** Cat. no. **Y28A**

Designed for:

Manufacturer: **HONDA**

Model: **ACCORD TOURER**

Type: **Estate (CM1, CM2, CN2), except Type S,**

produced since 05.2003 till 07.2008

Approval number according to Directive 94/20/EC: **e20*94/20*0978*00**

Technical data:

D-value: 8,56 kN

maximum trailer weight: **1500 kg**

maximum vertical cup load: **75 kg**

Foreword

This towing hitch is designed according to rules of safety traffic regulations. The towing hitch is a safety component and can be install only by qualified personnel. Any alteration or conversion of the towing hitch is prohibited and would lead to cancellation of design certification. Remove insulating compound and underseal from vehicle (if present) in the area of the matting surfaces of the towing hitch. The vehicle manufacturer's specifications regarding trailer load and max. vertical cup load are decisive for driving whereat values for the towing hitch cannot be exceeded.

D-value formula:

$$\frac{\text{Max trailer weight [kg]} \times \text{Max vehicle weight [kg]}}{\text{Max trailer weight [kg]} + \text{Max vehicle weight [kg]}} \times \frac{9,81}{1000} = D \text{ [kN]}$$